



## FINAL REPORT OF THE SIXTEENTH MEETING OF THE CBS MANAGEMENT GROUP



### CONTENT OF DOCUMENT:

The Table of Contents is available only electronically as a Document Map\*.

---

\* In MS Word 2007 or 2003, go to "View" > "Document Map". In MS Word 2010, go to "View" > "Navigation Pane".  
In MS Word on a Mac, go to "View" > "Navigation Pane", select "Document Map" in the drop-down list on the left.

## **DISCLAIMER**

### **Regulation 43**

Recommendations of working groups shall have no status within the Organization until they have been approved by the responsible constituent body. In the case of joint working groups the recommendations must be concurred with by the presidents of the constituent bodies concerned before being submitted to the designated constituent body.

### **Regulation 44**

In the case of a recommendation made by a working group between sessions of the responsible constituent body, either in a session of a working group or by correspondence, the president of the body may, as an exceptional measure, approve the recommendation on behalf of the constituent body when the matter is, in his opinion, urgent, and does not appear to imply new obligations for Members. He may then submit this recommendation for adoption by the Executive Council or to the President of the Organization for action in accordance with Regulation 9(5).

© World Meteorological Organization, 2016

The right of publication in print, electronic and any other form and in any language is reserved by WMO. Short extracts from WMO publications may be reproduced without authorization provided that the complete source is clearly indicated. Editorial correspondence and requests to publish, reproduce or translate this publication (articles) in part or in whole should be addressed to:

Chairperson, Publications Board  
World Meteorological Organization (WMO)

7 bis, avenue de la Paix

P.O. Box No. 2300

CH-1211 Geneva 2, Switzerland

Tel.: +41 (0)22 730 84 03

Fax: +41 (0)22 730 80 40

E-mail: [Publications@wmo.int](mailto:Publications@wmo.int)

### **NOTE:**

The designations employed in WMO publications and the presentation of material in this publication do not imply the expression of any opinion whatsoever on the part of the Secretariat of WMO concerning the legal status of any country, territory, city or area or of its authorities, or concerning the delimitation of its frontiers or boundaries.

Opinions expressed in WMO publications are those of the authors and do not necessarily reflect those of WMO. The mention of specific companies or products does not imply that they are endorsed or recommended by WMO in preference to others of a similar nature which are not mentioned or advertised.

This document (or report) is not an official publication of WMO and has not been subjected to its standard editorial procedures. The views expressed herein do not necessarily have the endorsement of the Organization

## **FINAL REPORT OF THE SIXTEENTH MEETING OF THE CBS MANAGEMENT GROUP**

### **EXECUTIVE SUMMARY**

1. The sixteenth meeting of the CBS Management Group was held in Geneva from 15 to 19 February 2016.
2. CBS Management Group agreed the dates of CBS-16 to be 23 to 29 November 2016, with an associated Technical Conference on 21 and 22 November 2016. The Secretariat was working with the China Meteorological Administration (CMA) to make the arrangements following an offer from China to host the session in Guangzhou. CBS Management Group agreed a draft agenda for CBS-16, and decided that the topic of the TECO would be "Emerging Trends in Information and its Use." There would be a call for papers for the TECO. It also considered recommendations to EC-68 to form task teams to address specific issues.
3. CBS Management Group recommended a structure for the teams in CBS for the period 2017-2020, and recognized the importance of including capacity development, disaster risk reduction and the global framework for climate services in its work plan for that period.
4. CBS Management Group proposed a clarification of provisions in Manuals that could be amended using the simple (fast track) or standard (between sessions) procedures, and identified those provisions of Manuals to which it recommended those procedures may be applied.
5. CBS Management Group expressed its appreciation for the voluntary contributions made in support of its work by Members and experts. It confirmed that certificates of recognition would be awarded to experts during the CBS-16 session.

## 1. ORGANIZATION OF THE MEETING

### 1.1. Welcome and objectives

7. Mr Branski, President of the Commission for Basic Systems opened the meeting at 0900 on Monday 15 February 2016. He outlined the topics to be discussed at the meeting, and noted that there would need to be flexibility in the scheduling to allow break out sessions.
8. Mr Taalas, Secretary-General of WMO, addressed the meeting. He highlighted the critical role of CBS as the most important Technical Commission and provided the backbone for all WMO activities. Although Cg-17 had called for a revision of the technical commission structure and the contents of their meetings that would be a topic at the EC WG SOP being held in parallel with CBS MG-16, the Secretary-General was convinced that the activities supported by CBS would remain. The key issue was how to make best use of resources – at the Secretariat and in Members. Often the most appropriate experts did not participate because of a lack of perceived relevance of the work to WMO. WIS and WIGOS implementation remained important activities to be delivered and Cg-17 had requested CBS to take the leading role in the WIGOS pre-operational phase. The private sector was becoming more active, with increasing initiatives in data creation and delivery. EC-68 would address interaction with the private sector. He reminded the CBS Management Group (CBS-MG) that Members extended beyond the NMHS and included the private sector. He had initiated a process of change of the WMO secretariat to become more user-focussed. Finally, he thanked members for attending, and looked forward to meeting them at CBS-16 in China.
9. Mr Branski responded that the meeting would be discussing what the strategic approach should be, taking into account potential changes to the structure of technical commissions. The meeting would be focussing on a more strategic approach to the structure of the CBS-16 session. CBS had striven to improve its efficiency and effectiveness, and aimed to continue to do so.
10. Dr Barrell thanked S-G for addressing the meeting, and supported the fundamental role of the basic infrastructure of systems, noting that a better understanding was needed of what those systems should be in the future, and how Members should go about ensuring that they were available to them. Although CBS had shortened its sessions, a consequence was that the session in Paraguay had perhaps pushed decisions through too quickly and had not provided enough time for formal and informal discussions, or to encourage development of experts, and so even shorter sessions would be unlikely to deliver the required outcomes.
11. Mr Taalas recommended that more information was needed for governments on the importance of infrastructure. He also suggested that one option might be to hold smaller meetings once a year, with larger meetings every four years.
12. Mr Branski, noted that the extraordinary sessions and “fast track” procedures were designed to allow decisions to be made between main sessions in order to keep pace with technological change. The WMO decision making process would need to be reviewed to ensure that it remained capable of keeping up with the rate of external change that WMO would need to handle in the future. He also commented that the data processing and forecasting system would need to be reviewed, including service provision, to ensure that it met the needs of the whole WMO community.
13. Mr Jean thanked the S-G for his open approach and accessibility. While acknowledging the costs and our obligation to optimize the use of resources, he noted the importance of having material available in the languages used by Members; this was particularly important at times of rapid change and will be critical in the years to come. The world was changing at a different pace from the decision making time scales of WMO.

14. Mr Taalas acknowledged the importance of publishing in many languages, but considered that the cost of translation was high, so a more pragmatic approach might be possible that ensured comprehension at lower cost. He was concerned that WMO should be a more effective organization, with less time on reporting what had happened to free time for discussion on future activities. Customer orientation was to be supported, and more effective capacity development was required. The secretariat had a "silo" structure that limited the ability of the secretariat to work in a coordinated way across the whole range of activities. External organizations saw the work of NMHS as an opportunity for expansion, and although this offered opportunities, if not handled appropriately it could also threaten the quality of information available. The implementation of the COP agreement had to be achieved. Including the routine monitoring of greenhouse gas concentrations. Sendai outcomes also offered opportunities for the WMO community.
15. Mr Branski, commented that there were challenges in working with the GFCS.
16. Mr Fleming commented that it was difficult to obtain experts from smaller countries, and such involvement would improve relations between CBS and those countries. A similar interaction with the private sector would also improve the relationships.
17. Mr Taalas replied that involving smaller countries was important, not least to ensure that WMO addressed issues of concern to them. This also applied to research and technical experts.
18. Mr Lengoasa, Deputy Secretary-General, welcomed participants. He noted the importance of the meeting given the session of CBS late in 2016, the challenges in the global economy, and the gradual decline in basic systems in response to financial constraints in NMHS. He noted that the African Ministerial Conference had been formed, and that it was a forum for emphasizing the need for basic systems. He thanked the President, Vice-President and the members of the Management Group for their valuable leadership.
- A1 Mr Branski asked the Secretariat to distribute the outcome of the EC WG SOP to CBS-MG members.
19. Dr Zhang, Director of Observing and Information Systems, welcomed the members of the CBS Management Group, and noted that the EC WG SOP was meeting in parallel with CBS-MG.
20. Participants in the meeting are listed in [Annex 1](#).

## **1.2. Adoption of the agenda**

21. The agenda in [Annex 2](#) was adopted.

## **1.3. Working arrangements**

22. The working arrangements for the meeting were agreed.
23. Dr Barrell would brief CBS-MG on the outcomes of ICG-WIGOS-5 under the WIGOS agenda item 5.3.

## **2. ORGANIZATION OF CBS-16**

### **2.1. Date and location of CBS-16**

24. Dr Zhang informed CBS Management Group that the sixteenth session of CBS (CBS-16) was expected to be held from 23 November to 29 November 2016, preceded by a Technical Conference on 21 to 22 November. Sunday 27 would be a rest day. CMA had offered to host the meeting in Guangzhou.
25. Ms Li (CMA) outlined the preparations made by China for hosting CBS-16. China expected that the WMO Secretariat would develop an alternative to the Google-based system

normally used for hosting meeting documentation. China had budgeted for a six day session.

26. The proposed hotel was the Guangzhou Dongfang Hotel, minutes from the international airport).
27. Dr Zhang reported that the WMO IT Department were already investigating alternatives to the Google infrastructure, because it was not only China that had problems using that infrastructure.

## **2.2 Topic and timing of TECO**

- D1 CBS Management Group decided that a 2-day TECO would be held during the two days before the CBS-16 session.
28. CMA would investigate the possibility of holding an exhibition in parallel with the TECO and for the first one or two days of CBS-16.
29. Following discussions on potential content of the TECO associated with CBS-16, a sub-group led by Dr Barrell agreed on the theme and broad content of the TECO, and developed a concept note for TECO during the meeting. That note was presented to the meeting.
- A2 The concept note on the TECO would be further developed. Members would be invited to offer papers; the wording used by CIMO inviting contributions to their TECO would be used. This would be coordinated by Mr Shi, who would be the secretariat lead in arrangements for the TECO.
- D2 CBS Management Group decided that the topic of the Technical Conference would be "Emerging Trends in Information and its Use".
- A3 The announcement of the TECO would be sent with the CBS-16 announcement by the end of March.
30. Members would have until EC-68 to respond to the call for papers for TECO, after which a programme committee consisting of Dr Barrell, Mr Jean, a representative of CMA and the OPAG chairs would select the papers to be presented.
31. There would be 4 keynote papers, for example cloud computing, data analytics, social media, high density services (urban) of 30 minutes duration, standard papers of 15 minutes, and 30 minute panel discussions.
32. The daily programme would have a 4h morning session and a 5h afternoon session, each with a 30m break. Over two days, TECO would be divided into 7 blocks of 1h 45m, each with 4-5 presentations and a panel discussion/Q&A. The 8<sup>th</sup> block would be a summary discussion; this left some time to provide flexibility.
33. It was not clear whether it was appropriate to have a poster session. This was left to the discretion of the local organizers, but a small allocation of time could be made in the TECO programme for the posters to be introduced.
34. The first day would concentrate on technical implications of big data, and the second on using big data.
- D3 Five lunchtime TECO Focus sessions would be planned. There would be one for each OPAG. Reaching a conclusion on the topic of the fifth would be coordinated by Dr Barrell.
- A4 The future of the GDPFS, possibly including changes to the manual, should be allocated time in the main session, as part of the strategy discussion, as the discussion needed to be interpreted. This also needed to be discussed in the TECO.

### **2.3. CBS-16 agenda topics and structure**

35. Mr Branski commented that the EC WG SOP would be considering the future structure of Technical Commissions. One of the options being considered was reducing the number of Technical Commissions. CBS-16 was the largest Technical Commission, and would be the first to meet since CG-17. CBS-16 would provide an opportunity to test any streamlining proposals from EC WG SOP and to provide valuable feedback.
36. There was wide support from CBS-MG that CBS-16 should take a more strategic focus than in the past, especially at a time when the WMO governance was under review, there was a strong push from the new S-G to reduce time spend on reporting and to streamline processes.
37. Mr Branski reminded CBS-MG that the agenda identified the topics to be covered, and that they could be scheduled in the work plan in a different order if that better suited the needs of the session.
38. Each OPAG chair should have an opportunity early in the session to lay out the key issues facing them. Reporting should be forward-looking, highlight significant achievements and challenges, but focus on what should happen in the future.
39. The strategic concepts could be introduced on the first day, heralding a more detailed discussion of strategic issues on the second day (to allow time for the report of TECO to be translated).
40. Mr Dibbern thought that the draft structure of the strategic option provided a useful framework to lead the discussions in a logical way. He considered that the decisions on technical regulations could be made before the strategic discussions. This would allow the time for the TECO report to be prepared.
41. Mr Branski considered it important for CBS-16 to discuss an improved decision making methodology for future decisions (as an alternative to an Extraordinary session). Such a process would be needed to avoid having to systematically use the "exceptional" process of approval by the President of WMO.
42. CBS-16 should debate whether there was case for an extraordinary session to be held in 2018, bearing in mind the guidance from EC-65 that a clear single topic needing timely decision was needed to make the case for an extraordinary session. The outcome of this discussion would inform CBS-MG on whether to make a case to EC-69 to hold an Extraordinary session.
- D4 The draft agenda for CBS-16 at [Annex 3](#) was adopted. The sequence of agenda items should follow the running order as far as possible, and the strategic item should appear after the changes to technical regulations. Guidance on the detailed topics for the strategic discussion should be included in the annotated agenda.
- A5 Mr Branski asked that the draft agenda be adjusted to show the order of discussion and the work plan should also be drafted.
- D5 CBS Management Group noted that CBS-16 would need to include administrative decisions that were not required by CBS Ext.(2014), and therefore would require at least five days of discussion, as well as time to conduct the elections.

### **2.4. Review of the performance of CBS**

43. CBS Management Group considered the report of the Chair of OPAG IOS on progress with the OPAG IOS work plan ([input document D03](#)).
44. CBS Management Group considered the report of the Chair of OPAG ISS on progress with the OPAG ISS work plan ([input document D04](#)).
45. Mr dell'Acqua presented the initial vision for the evolution of WIS that had been developed by ICT ISS and possible options to reach it. ICT ISS would develop this into a global strategy for the evolution of WIS.

46. A security incident at a centre connected to the RMDCN had highlighted a need for a standard approach for WIS centres to react to such events to minimize the impact on the WIS. The proposed solution was to implement a trusted WIS Computer Emergency Response Team, and a proposal was expected to be presented to CBS-16.
47. CBS Management Group considered the report of the Chair of OPAG DPFS on progress with the OPAG DPFS work plan ([input document D05](#)).
48. It was noted that the demand for SWFDP was increasing, but that resources were limited. The SWFDP was funded, essentially, through extra-budgetary mechanisms. Dec 2015 marked the end of many funding mechanisms that had allowed the implementation of the SWFDP in parts of the world. Work was underway with the resource mobilization division to secure funding for the continuation of the project in current areas and for its expansion into new areas.
49. CBS Management Group considered the report of the Chair of OPAG PWS on progress with the OPAG PWS work plan ([input document D06](#)).
- A6 Mr Branski asked for future work plans to be developed in a standard format based on the OPAG IOS document presented to CBS-MG-16 (annex 1 of [input document D03](#)). Each task should have an identifier consisting of the team name and a sequential number. The headlines of these should be included in the documents submitted to CBS-16 as a link to a file held on the web that contained the in tabular form of the work plan (the file would not be modified following approval of the CBS report). Ongoing (version-controlled) copies should be published and maintained on the web.
- A7 Mr Branski asked that the 2012-2016 work plans should be summarized in the CBS documents reporting progress. He asked for them to be translated if they were formally submitted to the CBS-16 session.

### **3. STRUCTURE OF CBS 2017-2021**

#### **3.1. CBS Terms of Reference**

- D6 CBS-MG concluded that the Terms of Reference for the Commission of Basic Systems in WMO No. 15 2012 Edition (Annex D07/1) included the requirement of Resolution 25 (Cg-17) for CBS to lead on managing changes to the Manual on WIGOS.
- D7 CBS-MG recommended that the Terms of Reference for the Commission for Basic Systems adequately covered the data management aspects of "Part C" of the WIS.
- D8 CBS-MG discussed item (g) in the terms of reference of CBS (GDPFS) and whether it captured the role of the GDPFS or duplicated items (k) and (l). CBS-MG concluded that item (g) remained appropriate.

#### **3.2. CBS Structure - OPAGs and Expert Teams**

- D9 CBS-MG recommended that the OPAG structure still met the requirements of the CBS.
- D10 CBS-MG recommended that the composition of the CBS-MG should be that shown in Table 1 of the Final Report of CBS-MG-16.

**Table 1. Proposed composition of CBS Management Group.**

<b>CBS MG Member</b>	<b>Specific MG Responsibility (Associate members do not have voting rights; other classes of membership have full rights)</b>
President	Chair.
Vice-President	Co-Chair
Chair OPAG IOS	Core Member
Co-chair OPAG IOS	Core Member
Chair OPAG ISS	Core Member
Co-Chair OPAG ISS	Core Member
Chair OPAG DPFS	Core Member
Co-Chair OPAG DPFS	Core Member
Chair OPAG PWS	Core Member
Co-Chair PWS	Core Member
DRR coordinator	Core Member
Chair SG-RFC	Associate Member (if needed to contribute to discussions on matters impacted by radio frequencies).

- D11 CBS-MG decided to propose to CBS-16 the continuation of the role on CBS MG of a CBS DRR coordinator with the adding responsibility for capacity development related to disaster risk reduction to the terms of reference agreed by CBS-15.
- D12 CBS-MG decided not to continue the role of CBS Capacity Development coordinator and to add capacity development coordination to the terms of reference of all OPAGs, and to add responsibility for capacity development to the terms of reference of the coordinator on Disaster Risk Reduction.
50. CBS-MG considered the relationship of CBS with GEO. It considered that interactions with GEO had matured, and noted that WMO, through D/OBS, was an observer on the GEO Programme Board. It further noted that this had been achieved through the strategic emphasis and drive that had been provided by the coordinator.
- D13 CBS-MG decided that it no longer required the role of CBS Group coordinator on GEO and GEOSS activities related to WMO.
51. CBS-MG considered a proposal to add a coordinator on strategic aspects such as public-private partnerships or big data, noted that EC WG SOP was considering such areas of focus, and concluded that it was too early to make a decision.
52. CBS-MG would propose additional coordinators to CBS-16 if required, guided decisions at EC-68.
- D14 CBS-MG confirmed that the Task Team on migration of upper air reports to BUFR should continue until it had completed its tasks.
53. CBS-MG noted the recommendation from SG-RFC that the SG-RFC should report directly to CBS-MG that had been made to emphasize the strategic importance of radio frequency issues.
- D15 CBS-MG decided that the SG-RFC should retain its relationship with and report to to OPAG IOS, but that it should also provide reports directly to CBS-MG.

- D16 CBS-MG noted the political aspects of radio frequency issues, and decided that the Chair of SG-RFC should be an associate member of CBS-MG without voting rights.
54. [Annex 4](#) contains the draft Terms of Reference (TOR) for the OPAGS and [Annex 5](#) contains the TOR for the teams within the OPAGs that would be developed into versions suitable for recommendation to CBS-16.
- A8 CBS-MG asked each OPAG to present its structure to CBS-16 as an organogram in addition to the standard text representation, and that the full as well as abbreviated team names should be included. These organograms should use a consistent symbology and colour scheme and differentiate between teams and roles of individuals (derived from the DPFS design).
- D17 CBS-MG decided on the following standard nomenclature for its teams:  
*ITT*: Inter-Commission Task Team (where the responsibility is joint between Commissions; fixed life);  
*IPT*: Inter-Programme Team (where responsibility is joint between Commissions; no set life);  
*IPET*: Inter-Programme Expert Team (where the responsibility is primarily CBS);  
*ET*: Expert Team;  
*TT*: Task Team (a team under an OPAG authorized by President CBS);  
*Ad hoc Task Team*: short-lived team for specific task authorized within an OPAG;  
*Coordinator*: individual with defined responsibilities;  
*Representative*: individual responsible for acting on behalf of another body;  
*Focal Point*: national, Commission or Programme coordination role.
- A9 Noting the gender distribution of experts in its teams, CBS Management Group urged Members to nominate female experts, and asked the secretariat to include this request in the letter inviting nominations of experts.
- A10 CBS Management Group asked the secretariat to prepare for CBS-16 statistics on the gender distribution of team membership decided by CBS (Chairs, Core Members) and of the nominations by Members (that is a second set of statistics that included associate members), and to use both sets when reporting to EC WG SOP.
- D18 CBS-MG confirmed the process of accepting all nominations as “associate members” of teams and selecting “core members” from these. Although all members of expert teams would be invited to meetings, normally only core members would be offered financial support to attend meetings. It was essential that the associate members were included in the discussions of expert teams.
- A11 CBS-MG asked each of the OPAGs to prepare by July 2016 a work plan for the period 2016-2020 for consideration by CBS-16, including capacity development.
- A12 CBS-MG asked that the nomination form asked for a justification of the nomination to each group that was nominated. It encouraged an online nomination procedure.
55. CBS-MG noted the structure of OPAG ISS. There were four expert teams, each of which had subdivided the work into subgroups that it had called “task teams”. Only one of the teams labelled “task team” contained members that were not part of the parent team; TT-AvXML consisted of a wider range of self-funded experts.
56. ICT-ISS has proposed that there would be three additional teams reporting to ICT-ISS. One corresponded to TT-CAC (Task Team on Centre Audit-Certification) whose role needed to be separated from the parent team for reasons of separation of duty. The other two task teams were teams for delivering specific tasks.
57. In response to a request from CBS, ICT-ISS had proposed adding a further team (SATCOM) reporting to one of its existing expert teams.
- A13 CBS Management Group asked OPAG chairs to develop work plans on the assumption that the budget approved by Cg-17 would be allocated.

58. Management Group consider the proposed structure for OPAG PWS that had been recommended by ICT PWS. It decided to recommend to CBS-16 that:
- D19 The name of the OPAG on Public Weather Services should be changed to the "OPAG on Public Weather Services Delivery (OPAG PWSD)".
  - D20 The structure of the OPAG should move towards the establishment of transient Task Teams (TTs) that would be focused on specific, time-bound, objectives.
  - D21 The areas of Communications, Competency Assessment, Service Delivery and Quality Management were fundamental enablers to the work of the OPAG, and that any Task Teams formed to address these areas would report directly to the ICT-PWSD.
  - D22 Chairs and co-chairs of Expert Teams, and of those Task Teams reporting directly to ICT PWSD at the time, would be members of ICT PWSD.
  - D23 The previous Expert Team on Communication, Outreach and Public Education (ET-COPE) would be dissolved and its responsibilities transferred to the ICT, and would then be devolved to specific Task Teams as would be established to address particular issues.
  - A14 ICT-PWS should establish a Task Team to work closely with the ETR Programme to assist in the development of suitable material to support Members in the implementation of the "Competency Framework for PWS Forecasters and Advisors" as approved by Resolution 4 of Cg-17.
  - D24 The previous Expert Team on Meeting User Needs in Reducing the Impact of Hydro-Meteorological Hazards (ET-DPM) should be re-named ET-IMPACT. That Expert Team should take over the responsibilities of the "Impact Advisory Group".
59. Possible focus areas for Task Teams to be established under ET-IMPACT might include specific country or region-based projects, social and economic benefit assessments, and the interface with users.
- D25 The previous Expert Team on Services and Products Improvement and (ET-SPII) would be retained to assist Members with the application of technological developments to the effective delivery of public weather services.
60. Possible focus areas for Task Teams to be established under ET-SPII might include Big Data, Nowcasting, application of the Common Alerting Protocol (CAP), further development of World Weather Information Service/Severe Weather Information Centre (WWIS/SWIC), GIS-compatibility of meteorological information, and the optimum exploitation of smartphone technology.
- D26 ET-SPII should work in close collaboration with the OPAG DPFS to facilitate the rapid and efficient application of new and emerging science and technology to improved service delivery.
  - D27 CBS Management Group recommended that there should be a Coordinator on Regional Association Liaison and a Coordinator on the Competency Framework on ICT PWSD.
  - D28 Terms of Reference for the two constituent Expert Teams within the proposed revised structure for the OPAG PWSD given in [Annex 5](#) were agreed for recommendation to CBS-16.
61. Mr Mylne noted that the GDPFS SWFDP and the PWS "learning by doing" projects were drawing on the same members of the secretariat for support, and that this sometimes caused resource issues that should be considered by the OPAGs when creating their workplans.
- D29 CBS Management Group recommended the structure for OPAG DPFS teams (see [Annex 5](#)); the terms of reference were still under development.
  - D30 CBS Management Group decided that in the proposal to CBS-16: the Steering Group on the Future GDPFS should report directly to CBS management group; ET-OSPLS should be renamed IPET-OSPLS.

D31 CBS Management Group decided that the proposal to CBS-16 on the structure of OPAG IOS should be that in [Annex 5](#). This had two less expert teams than during the period 2012-2016.

62. CBS Management Group noted that there were no experts in OPAG IOS that were qualified to fulfil the review of GCW regulations. If an expert could not be identified, the task would need to be added to the terms of reference of an OPAG IOS team, and an expert sought in the nomination process in association with CBS-16.

A15 CBS Management Group asked for the chair of the SG-GCW to be invited to the next meeting of the ICT-IOS in April 2016.

A16 CBS Management Group asked all OPAG chairs to complete the Terms of Reference for their OPAG teams. The terms of reference should include meeting the requirements for GFCS.

D32 CBS MG decided that the proposal to CBS-16 on the structure of OPAG ISS should be that in [Annex 5](#). The IPETs should retain as IPETs, but their names should be shorter than those approved by CBS-15.

A17 OPAG chairs should provide their updated Terms of Reference, organograms and updates to the report of CBS-MG-16 by 14 March, acknowledging that some OPAGs would need to modify these following their ICT meetings.

A18 Documents for CBS-16 should be provided to the secretariat before 12 August.

### **3.3. Joint teams with other Commissions**

63. Discussions, decisions and actions on joint working with other Commissions are recorded under agenda items 3 and 5.

## **4. CONTENT OF AND RESPONSIBILITY FOR PREPARING DOCUMENTS FOR CBS-16 ON PRIORITY TOPICS**

### **4.1. OPAG IOS**

64. CBS Management Group considered the proposed topics proposed by OPAG IOS for discussion at CBS-16.

#### **4.1.1 Future Structure of the OPAG IOS**

#### ***Integration of IPET-WIFI activities into ICG-WIGOS***

D33 Noting the recommendations in [input document D09](#), CBS-MG recommended that the IPET-WIFI activities should be fully integrated in the ICG-WIGOS teams or other CBS expert teams after CBS-16 and the IPET-WIFI dissolved.

A19 CBS-MG requested the ICT-IOS to discuss how the IPET-WIFI activities could be fully integrated in the ICG-WIGOS teams or other CBS expert teams after CBS-16 allowing the IPET-WIFI to be dissolved. Proposal should then be made to CBS-16.

D34 CBS Management group agreed with the proposal by ICG-WIGOS-5 for the ICG-WIGOS subsidiary expert teams.

65. Dr Barrell, on behalf of ICG-WIGOS, thanked the CBS expert teams for their contributions to WIGOS.

### **Formation of a WMO Weather Radar Coordination Team**

66. CBS-MG noted the background information in [input document D33](#) on the proposed WMO Weather Radar Coordination Team

D35 CBS-MG recommended that a WMO weather radar coordination group should be established to take on the role of a coordination group for radar systems for the wider WIGOS and not just in support of the applications under the WWW. It should be formed as an Inter-programme Expert/Task Team under the authority of CIMO and CBS Management Groups and under leadership of the relevant OPAGs in the two TCs.

A20 The Group requested the OPAG IOS Chair, Mr Jochen Dibbern, to review the current draft Terms of Reference of the weather radar coordination group in liaison with CIMO and the Secretariat, and to make a proposal on behalf of the CBS Management Group at the CIMO Management Group meeting (Offenbach, Germany, April 2016). Once the Terms of Reference had been agreed by both Management Groups (by correspondence as necessary), the membership would be proposed and the formation of the coordination group submitted to EC-68 for establishment in line with the requirements WMO Regulations 38, 39. CBS-16 and the next CIMO Session (2018) would then be invited to note establishment of the group, and possibly propose further changes to its Terms of Reference and membership.

### **Steering Group on Radio-Frequency Coordination (SG-RFC)**

67. CBS-MG noted that the Steering Group on Radio-Frequency Coordination (SG-RFC) had emphasised the need to gain representation from all ITU regional organizations on the SG-RFC. It had also expressed some concern that the move from ICT-ISS to ICT-IOS had not fully addressed the challenging and crosscutting nature of its work and would like CBS to review this issue.

#### **4.1.2 Sixth WMO Workshop on the Impact of the Various Observing Systems on NWP, Shanghai, China, May 10-13 2016**

68. CBS-MG noted the information on planned Sixth WMO Workshop on the Impact of the Various Observing Systems on NWP that had been provided in [input document D09](#) More information was on the meeting web page: <http://www.wmo.int/pages/prog/www/WIGOS-WIS/meetings.html>.

#### **4.1.3 Key OPAG IOS topics from the Expert Teams for the Management Group to consider**

69. CBS-MG discussed and concurred with the key topics under each of the OPAG IOS Expert Teams for decision by the CBS-16 contained in [input document D09](#).

D36 CBS-MG ratified the decision by ICG-WIGOS-5 to establish a WIGOS Review Editorial Board to ensure harmonization and synchronization of all contributions to WIGOS regulatory material from different teams.

## **4.2. OPAG ISS**

### **4.2.1 WIS**

70. Mr dell'Acqua asked the Management Group to note the proposed contents of the WIS documents for CBS-16 that were listed in [input document D10](#). He highlighted the ad hoc task team (ITT-WIS; Inter-Commission Task Team on WIS) that would create a process for prioritization of data streams to ensure that telecommunications facilities transferred the most beneficial information; EC-68 would be asked to approve the formation of that team..

71. Part C of the WIS would address the information management life cycle, and would need a task team to develop the initial guidance on integrated management of data and

information. Dr Barrell commented that the task team would need to work closely with the ICG-WIGOS task team on data and partnerships.

72. The Task Team on Centre Audits and Certification needed to be populated by experienced experts in quality management audits, and its current location under ET-WISC introduced conflicts of interest between those developing the specifications and those auditing their implementation. ICT ISS considered that moving TT CAC to report directly to ICT ISS would remove the conflict of interest and also provide a mechanism for attracting suitable qualified experts.
73. CBS-MG recognized that a team in quality auditing could serve all CBS centre registrations rather than being limited to WIS centres.
74. Mr Mylne reported comments from Mr Tandy (Chair IPET-MDRD) that typically there was more work to be done than could be handled by experts in OPAG ISS, but that Members were also developing systems for their own use. He suggested that more progress might be made if these developments were identified and the expert teams selected those that were suitable for more general adoption.

#### **4.2.2 Climate Data Management Specifications**

75. CBS-MG noted [input document D26](#) on climate data management specifications. The approved definition of the functionality expected within a CDMS was available in WMO-No 1131, [https://googledrive.com/host/0BwdvoC9AeWjUazhkNTdXRXUzOEU/wmo\\_1131\\_en.pdf](https://googledrive.com/host/0BwdvoC9AeWjUazhkNTdXRXUzOEU/wmo_1131_en.pdf).
- A21 CBS-MG noted that CCI had already approved the text of the CDMS specification, and that CBS Ext.(2014) had asked that these specifications should be incorporated into the WIS documentation. CBS-MG asked ICT ISS to prepare text that incorporated the CDMS specifications in the WIS documentation.
- A22 CBS-MG asked OPAG ISS to consider an appropriate procedure for future updating of the CDMS in the WIS regulations if required by CCI.
- D37 CBS-MG agreed that the CDMS specifications would be considered in the process of developing Part C of the WIS.
- A23 CBS-MG asked ICT ISS to ensure that there was appropriate CCI representation on the task team addressing data management.

#### **4.3. OPAG DPFS**

- D38 CBS Management Group considered and agreed the topics proposed by OPAG DPFS for discussion at CBS-16 contained in [input document D11](#).
- A24 CBS-MG asked the OPAG DPFS to accelerate the implementation of the mechanism approved by Cg-17 to strengthen operational centres, built upon the lessons learned through the Severe Weather Forecasting Demonstration Project.
- A25 CBS-MG urged the Secretariat to explore opportunities for additional donor funding to support the ongoing development of individual SWFDP projects and the central support for training.
- A26 CBS-MG requested the OPAG DPFS to liaise with the relevant Regional Associations to identify regional entities that would support the SWFDP project beyond its operational phase.
76. Mr Jean suggested that the observation monitoring activities might allow near real time estimation of the relative contributions of components of the observing system.
77. Dr Barrell recommended that DPFS should be careful when using the word "seamless" and if possible find a phrase that has fewer preconceptions associated with it, otherwise (as for

WIS and WIGOS), the team would spend a disproportionate amount of effort explaining the scope and context of the work.

78. Dr Zhang informed the group that WIGOS was planning a workshop to develop the vision for surface observations in 2040, and that a contribution from OPAG DPFS to that workshop would be valuable.
79. Mr Branski reminded CBS MG that World Meteorological Centres (WMCs) were not purely technical centres, and that any change in the definition of a WMC would have ramifications wider than the scope of the Manual on GDPFS, for example WMC operators had automatic seats on WMO Bureau. The proposals by OPAG DPFS would need to take this into account.
80. In common with other OPAGs, OPAG DFPS potentially had more work than resources to deliver the developments and turn these into operations.

#### **4.4 OPAG PWS**

81. CBS Management Group considered the proposed topics for discussion at CBS-16 proposed in [input document D12](#) relevant to OPAG PWS and agreed them. It also noted the progress reports in that document.
82. CBS-MG noted that it would be impossible for the OPAG PWS to tackle all identified areas of work within the resources available – those resources being primarily made up of the time of the experts who contribute to the Expert Teams, the Task Teams and the ICT-PWS itself. CBS Management Group advised ICT PWS that many of the priority items overlapped with other OPAGs, so that ICT PWS could work with other ICTs to deliver what was required.
- A27 CBS-MG asked the ICT-PWS to provide some clear and realistic guidance as to which of the identified work items should be prioritised and to propose the resulting work plan to CBS-16.

### **5. STRENGTHENING CBS CONTRIBUTIONS TO WMO STRATEGIC PRIORITIES**

#### **5.1 Disaster Risk Reduction**

83. Mr Jean briefed Management Group on the key aspects of the Sendai Framework that changed the focus from managing disasters to disaster risk management, assisted by the use of science and technology in policy making ([input document D13](#)). Multi-hazard early warning systems and their extension to additional types of hazard, for example biological, were a fundamental component of risk management with a particularly strong link to WMO activities, and there was a Sendai target and indicator (g) of *substantially increasing the availability and access to people of multi-hazard early warning systems and disaster risk information and assessments by 2030*.
84. The draft WMO Disaster Risk Reduction roadmap was being published at <http://www.wmo.int/pages/prog/drr> (the draft at the time of the meeting was [http://www.wmo.int/pages/prog/drr/documents/2016.01.20-WMODRRRoadmap\\_Zero-Draft-V1.1.pdf](http://www.wmo.int/pages/prog/drr/documents/2016.01.20-WMODRRRoadmap_Zero-Draft-V1.1.pdf)).
85. WMO used a network of Regional Association, Technical Commission and Technical Programme focal points to coordinate the work on disaster risk reduction.
- A28 Mr Branski asked the DRR Programme to extract from the WMO Disaster Risk Reduction roadmap those deliverables required from CBS.
- A29 CBS-MG asked all its OPAGs to include requirements stemming from the Sendai Framework and the WMO Disaster Risk Reduction roadmap when developing their Work Plans for presentation at CBS-16.
86. Management Group noted that there was an EC working group on disaster risk reduction and debated the most appropriate location for the task team requested by Cg-17.

D39 CBS-MG recommended to EC-68 the establishment of an Inter-Commission Task Team to address Cg-17's decision to: standardize identifiers for cataloguing of weather, water, climate, space weather and other related environmental hazard and risk information for cataloguing extreme weather, water and climate events (Resolution 9 (Cg-17)).

D40 CBS-MG also recommended to the EC Working group on Disaster Risk Reduction that the DRR governance structure should be adapted to place more emphasis on delivery rather than advisory groups.

### **5.1.1 Tropical Cyclone Programme**

87. CBS Management Group noted the discussions at Cg-17 on the Tropical Cyclone Programme (TCP) and the Tropical Cyclones RSMCs/TCWCs Technical Coordination Meeting (TCM), and also be background material on the topic provided in [input document D13-1](#).

88. CBS Management Group discussed possible ways for enhancing the Tropical Cyclones RSMCs/TCWCs Technical Coordination Meeting (TCM) role in global coordination of techniques and incorporating the TCM within WMO governance structure. CBS-MG considered the positioning of TCP within the WWW and CBS in consideration of the strong links with GDPFS, PWS and other programmes to improve coordination and in DRR services.

D41 The MG recommended to the Tropical Cyclones RSMCs/TCWCs Technical Coordination Meeting (TCM) that TCM should find a way to enhance and formalize its roles within the WMO governance structure. It also suggested to TCM that TCM assess the advantages and disadvantages the existing situation to help guide the decision on the way forward. Regardless of the decision, CBS would ensure that its activities supported the Tropical Cyclone Programme.

## **5.2 Global Framework for Climate Services**

### **5.2.1 CBS Support to GFCS - GOS**

89. CBS-MG noted the information in [input document D14-1](#) on the role of WIGOS and the Global Observing System to the Global Framework for Climate Services (GFCS), and in particular their contributions to the Monitoring Pillar of GFCS

90. CBS-MG concluded that the GFCS community should clearly articulate the role of WIGOS role in the Observation and Monitoring Pillar, as well as the expected contributions from WIGOS in terms of data and systems.

91. D/GFCS Office and PM/WIGOS had been requested by ICG-WIGOS-5 to jointly propose a way forward, based on lessons learned from WIGOS participation existing GFCS pilot projects. PM/WIGOS had been requested to report ICG-WIGOS-6 on progress achieved.

### **5.2.2 CBS Support to GFCS - WIS**

92. CBS-MG noted the information in [input document D14-2](#). The WIS was intended to serve the needs of all WMO and partner programmes; it could and would support GFCS.

93. The CSIS pillar of GFCS would need information to be exchanged between organizations that were accustomed to handling different types of data. CBS could help GFCS standardize on data representations, and could maintain controlled vocabularies that support information exchange without GFCS having to create a new methodology.

94. The WIS already provided mechanisms for the routine exchange of information as well as fulfilling ad hoc request, but much of the infrastructure was inherited from handling information relevant for synoptic meteorology. The infrastructure was capable of expansion to handle the needs of GFCS.

### **5.2.3 CBS support to GFCS – DPFS**

95. CBS-MG noted the information provided in [input document D14-3](#). Seasonal forecasts that might involve extremes such as droughts, unusual floods or high number of tropical cyclones, would require a “seamless” service to contribute to the Climate Services Information System (CSIS) and the User Interface Platform (UIP), using both climate and weather timescale products. OPAG-DPFS had been working with CCI on the development of the concept of a Seamless Weather and Climate Watch for operational monitoring and anticipating extreme meteorological events, with plans for demonstrating of its effectiveness in Eastern Africa. This would also contribute to the GFCS Capacity Development Exemplar.
96. CBS/DPFS and DPFS Programme and CCI had collaborated in projects related to: strengthening existing and establishing new Regional Climate Centres (RCCs); (2) establishing and coordinating operational support for frameworks for climate services; (3) strengthening cooperation and enhanced exchange of data, methods and tools between GPCs and RCCs, and ways to improve operational practice in long-range forecasting, including in support of NMHSs and RCOFs; (4) standardizing and promoting the use of operational CSIS products; (5) developing and producing the Global Seasonal Climate Update (GSCU); and (6) capacity development, including training on the use of operational climate prediction products. These projects contributed to the CSIS of GFCS, and to the GFCS Capacity Development Exemplar.

### **5.2.4 CBS support to GFCS – PWS**

97. CBS-MG noted the information provided in [input document D14-4](#), and in particular the contribution of the Public Weather Services Programme to the GFCS UIP.
98. While no formal links had been established between the OPAG PWS and the GFCS UIP, many of the Guideline documents prepared under the auspices of the OPAG and the PWS Programme would act as key resources in the establishment and maintenance of good communication practices between providers and users of climate services.

### **5.2.5 Summary of GFCS-related actions required**

99. Mr Lucio outlined that the WMO would contribute to the GFCS through five objectives. The objective directly impacting on Technical Commissions was the provision of guidelines, standards, capacity development, materials and other tools to support country-level implementation of basic systems and support for disaster risk reduction. The objective on institutional infrastructure included the establishment of institutional infrastructure, including establishment of the CSIS backbone to include seasonal to climate change predictions (through the GDPFS) and making data and products available in an organized structure (through the WIS). He described the draft climate services toolkit that had been developed with the assistance of CCI.
- A30 CBS Management Group noted that the DRR roadmap provided tangible requirements that CBS could address, and suggested that the Director of the GFCS Office might provide similar guidance to Technical Commissions on GFCS requirements.
- D42 CBS Management Group considered that developing the basic systems in support of GFCS was already included in the Terms of Reference for CBS, and that the Commission was well placed to lead in capacity development of the basic infrastructure.

## **5.3 WMO Integrated Global Observing System**

### **5.3.1 Outcome of ICG-WIGOS-5**

100. Dr Barrell outlined the outcomes of ICG-WIGOS-5. WIS and WIGOS had generalized the GTS and Integrated Observing System, and Dr Barrell expressed a view that the next step was a similar generalization of the GDPFS.

101. The five priority areas for WIGOS implementation were:
- 101.1. National WIGOS implementation
  - 101.2. Regional WIGOS centres
  - 101.3. WIGOS Information Resource
  - 101.4. WIGOS Data Quality Monitoring System
  - 101.5. WIGOS Regulatory and Guidance Material
102. ICG-WIGOS had noted that Regional WIGOS centres were likely to have different specifications in each region, but that each was expected to provide observation monitoring and feedback to Members.
103. WIGOS was expected to become operational by 2019.
104. ICG-WIGOS-5 proposed that there should be three co-chairs of ICG-WIGOS: from CBS, CIMO and EC.
105. The aim of ICG-WIGOS was for every Member to be “WIGOS ready” by Cg18 (2019). The criteria for a Member to be “WIGOS ready” was:
- WIGOS metadata implemented;
  - WIGOS station identifiers implemented;
  - OSCAR implemented;
  - Data Quality Monitoring – national processes in place;
  - Embracing all NMHS-operated observing systems (and willing partners).
106. In addition, ICG-WIGOS expected that on the same time scale:
- WIGOS would be progressively integrating partner systems;
  - Members would be supported by Regional WIGOS centres.
107. ICG-WIGOS-5 expected CBS to lead the work on developing the vision for WIGOS in 2040.
108. A remaining question for WIGOS was how it was going to be managed after 2019, when it stopped being a project.

### **5.3.2 Current WIGOS activities**

109. CBS-MG noted the information in [input document D15](#). CBS OPAG IOS and IPET-WIFI support for WIGOS was focused mainly on the development of the relevant technical regulations and related guidance material; metadata; data quality monitoring; OSCAR development; Guidance on the Observing Network Design (OND) Principles; RBON concept development; and on enabling satellite observations to contribute to all WIGOS component observing systems.

D43 Noting the strong support from ICG-WIGOS-5 for the proposal, CBS-MG decided to terminate IPET-WIFI and to integrate its activities into ICG-WIGOS and its task teams with strong involvement of CBS experts.

A31 CBS-MG asked ICT-IOS to plan for the termination of IPET-WIFI at its meeting ICT-IOS-9 in April 2016.

### **5.3.3 Future WIGOS activities**

110. CBS would continue to support WIGOS throughout the WIGOS Pre-operational Phase (2016-2019). EC-66 had stressed the importance of an early development of a “Vision for WIGOS in 2040” and had requested CBS to lead this development, with involvement of the other technical commissions.

111. ICG-WIGOS-5 had agreed that the vision for the space-based component should reflect the expectation that new and more efficient observing systems would be deployed in space, and that it should include material describing how the space-based component will contribute to the optimization of the surface-based component in order to arrive at an appropriate balance between space and surface observations. This should also reflect the need for surface-based, calibration, ground truth support for the satellite observations.
112. Regarding the priorities established by Cg-17 for the WIGOS Pre-operational Phase, CBS would contribute mainly in the following areas:
- 1) National and regional implementation:
    - o RBON concept development and implementation
    - o AWS network management
  - 2.1) Manual on WIGOS - drafting of technical regulations on:
    - o surface-based remote sensing (mainly weather radars and wind profilers),
    - o improving observational data and products quality and its monitoring,
    - o RBON,
    - o integration of the Manual on the GOS in the draft Manual on WIGOS (planned for the 2019 edition)
  - 2.2) Guide to WIGOS – drafting of guidance material on:
    - o Observing Network Design principles,
    - o RBON implementation,
    - o transition of existing observing systems to meet WIGOS requirements and standards,
    - o surface-based remote sensing (mainly weather radars and wind profilers),
    - o data quality and its monitoring,
    - o partnerships and data exchange
  - 3) WIGOS Data Quality Monitoring System (WDQMS).
  - 4) Regional WIGOS Centres (technical elements).
113. Mr Gusev noted that there were no formal terms of reference for regional WIGOS centres, so it was not clear to Members what the responsibilities of the centres should be. Mr Riishojgaard responded that Although Regions had decided that each region needed different functionality from their regional WIGOS centres, Mr Gusev advised that Terms of Reference were needed before Members could be asked to provide a regional WIGOS centre.

#### **5.3.4 PTC-2016 follow-up on "Big Data"**

114. Mr Grimes, President of WMO, described the challenges for WMO that he foresaw from "big data". He noted that at PTC it had become clear that trying to define "big data" constrained the assessment of risks and opportunities, rather than clarifying what was required. Whatever the definition, big data presented technical challenges, such as the different capacities of different NMHS to process large volumes of data, reducing the volume of available data to extract a more manageable amount of useful information, or extracting useful information from sources of uncertain quality. This needed the WMO scientific and technical viewpoints to be considered to complement the statements from generic information providers. The President had asked Presidents of technical Commissions prepare essays on the implications of Big Data to provide Permanent Representatives with the information they needed to make investment decisions.

115. CBS-MG noted Mr Grimes' presentation and the contents of documents [D28](#) and [D32](#).
- A32 CBS Management Group Members should pass any further thoughts on big data to Mr Branski.
- A33 The input would be used to draft a CBS essay within two weeks of the end of the meeting.
- A34 Mr Branski would remind other Commissions of what had been asked of them.

## **5.4 Aviation meteorological services**

### **5.4.1 Amendments of ICAO Annex 3 and WMO Technical Regulations, WMO-No. 49, Volume II, Meteorological Service for International Air Navigation**

116. CBS Management group noted the information in document [D16](#).
117. ICAO Annex 3 and WMO Technical Regulations, WMO-No. 49, Volume II, had been following an amendment cycle of three years established by ICAO. Amendment 77 would become applicable in November 2016 and after that a new two-year amendment cycle would be introduced (thus, AMD 78 was scheduled for 2018 and AMD 79 for 2020). Several expert teams in CBS supported the work of CAeM; the change in frequency of updates would impact on the work of those teams, and require a two-year approval cycle.
118. ICAO was planning to implement a delay of 12 months between an amendment to Annex 3 being approved and its implementation. ICAO's WG-MIE ICAO's WG-MIE was recommending to ICAO that technical changes should have an implementation date at least 18 months after approval to allow time for technical developments.

### **5.4.2 Restructuring of ICAO Annex 3 (WMO-No. 49 Vol 2)**

119. METDIV/14 agreed on the need for restructuring of Annex 3 (also known as WMO-No. 49 Volume II) and the development of a new set of provisions included in a document Procedures for Air Navigation Services – Meteorology (PANS-MET). In particular, the revised Annex 3 would specify service requirements whilst PANS-MET would specify means of complying with these requirements.
120. The task of coordinating with ICAO of the restructuring of Annex 3 had been assigned to the CAeM Expert Team on Governance (ET-GOV). ET-GOV would coordinate with relevant CBS subsidiary bodies concerning the impacts on the preparation and processing of relevant amendment material.
121. CAeM and CBS needed to discuss and coordinate a proposal for a WMO analogue of the ICAO PANS-MET to support a service-oriented Annex 3.

### **5.4.3 Participation in the work of ICAO MET Panel**

122. After METDIV/14, the ICAO Air Navigation Commission (ANC) established the MET Panel (METP) as the top-level ICAO body dealing with development and maintenance of regulatory provisions on meteorological information and services for aviation. The MET Panel was formed of four Working Groups.
123. The WMO nominated member on the MET Panel was Mr Dimitar Ivanov, C/AEM. Each METP member could nominate "advisers" on specific issues and tasks. The following WMO advisers had been nominated: Ian Lisk (UK Met Office, vice-president of CAeM); Steve Foreman, C/DRMM, on WG-MIE, also following the work of the ICAO Information Management Panel (IMP); Jérôme Lafeuille on WG-MISD WS on Space Weather (SpWx); Abdoulaye Harou, C/DPFS, on WG-MISD WS on Release of Radioactive Material (RRM).
124. CBS bodies supporting the tasks of the ICAO METP were: IPET-DRMM, IPET-MDRD, ET-ERA and ICTSW.

#### **5.4.4 Migration from TAC to IWXXM**

125. As part of the integration of the MET information into the ICAO SWIM interoperable environment, the Traditional Alphanumeric Code (TAC) information exchange (METAR, SPECI, TAF, SIGMET, etc.) would be replaced by the ICAO weather exchange model IWXXM using XML/GML. The CBS TT-AvXML (a sub-team of IPET-MDRD) had been supporting this transition and had already developed related provisions for the exchange of METAR, SPECI, TAF and SIGMET in XML/GML in the Manual on Codes, WMO-No. 306.
126. Amendment 77 (Nov 2016) removed the limitation of exchange to by “bilateral agreement” and made the “digital form” a normal recommended practice; it also contained new enabling provisions for the use of XML/GML for the exchange of volcanic ash advisories, tropical cyclone advisories and AIRMET information. This meant that TT-AvXML would need to develop the respective provisions for XML/GML encoding of these three types of information.
127. ICAO’s plan was to upgrade the provisions on the exchange of operational MET information in “digital form” to standards (mandatory) by 2020. Therefore, TT-AvXML together with CAeM ET-ETC, in coordination with relevant regional bodies, should identify and support the training needs of the WMO Members to facilitate the migration to XML/GML, but ICAO had not clarified its implementation and associated capacity development plans.
- A35 CBS Management Group asked OPAG ISS to ensure that the replacement of TAC by IWXXM was coordinated with developments on WMO systems so that there was no loss of information to production systems.

#### **5.4.5 Enhancing the provisions of information to aviation stakeholders on radioactive releases**

128. ET-ERA had been requested to assist the ICAO WG-MISD Work Stream RRM with development of enhanced provisions for the so-called “radioactive SIGMET”. This included guidance on the procedures and methodologies used by the relevant RSMC in support of the issuance of SIGMET by the Meteorological Watch Offices.

#### **5.4.6 Space weather**

129. ICAO had formulated a requirement for the development of operational space weather (SpWx) service for international air navigation. The ICTSW had been instrumental in providing advice to ICAO in developing the SpWx Concept of Operations (ConOps). The WG-MISD WS on Space Weather expects inputs from ICTSW (or its successor group) in finalizing the ConOps and developing relevant functional and performance requirements for the future global and regional Sp Wx centres serving international air navigation.

#### **5.4.7 ICAO SWIM and WMO WIS**

130. The ICAO GANP and ASBU performance improvements in all Air Traffic Management areas, including meteorology, were to be underpinned by the System Wide Information Management (SWIM) concept. There was a need for both ICAO and WMO to consider the interoperability of the SWIM and WIS, including related governance and data policy issues which would be very important for Members. Within WMO, such discussion should be held between relevant CAeM and CBS bodies (e.g., on the CAeM side, the ET-GOV and ET-ISA).
131. Mr dell’Acqua commented that ensuring compatibility between WIS and SWIM would involve the ET-WISC and ET-CTS teams within ICT-ISS.

#### **5.4.8 Aviation Research and Development Project (AvRDP)**

132. Cg-17 had supported the WWRP led Aviation Research and Development Project (AvRDP), working in collaboration with CAeM, to further develop nowcasting capability and mesoscale modeling techniques in support of next generation aviation products and

services. Congress had requested CBS, notably its OPAG-DPFS, to coordinate closely with CAeM in monitoring potential applications of the research being undertaken. The results of the AvRDP first phase would be reported at the WMO WWRP 4<sup>th</sup> International Symposium on Nowcasting and Very-short-range Forecast 2016 (WSN16), 25-29 July 2016, Hong Kong, and the planning for a second phase would be done at the same time.

#### **5.4.9 Volcanic ash information**

133. Development of requirements for information on volcanic ash was the responsibility of the Met Information Panel. ICAO expected that further observations would be needed. CBS would need to understand CAeM and ICAO's requirements in order to define its own work plans.
134. Volcanic Ash Advisory Centres were designated by ICAO but were operated by NHMSs and used techniques relevant to other specialized services. Inclusion of the VAACs in the specialized centres within the Manual on GDPFS should not create a problem, provided the Manual was clear that ICAO was responsible for the designation of such centres.

#### **5.5 Polar and high mountain regions**

135. CBS-MG noted document [D17](#) and recalled that following the completion of the development phase of the Global Cryosphere Watch (GCW) (2012-2015) and Cg-17 decisions, the GCW Programme (GCWP) had entered its Implementation Phase (2016-2019). CBS-MG recalled that Resolution 43 (Cg-17) had requested the Regional Associations and the Technical Commissions to include GCW in their work programmes in order fully to accommodate the cross-programme nature of GCW. The Group noted good progress in GCW development.
- D44 The Group concurred with the need for a CBS review of GCW Regulatory and Guidance materials for inclusion in the WIGOS Manual and Guide respectively. Those materials should be submitted by the GCW Steering Group; the review would be coordinated by the WIGOS Editorial Board (with assistance from OPAGs and CCI as appropriate).
- A36 CBS-MG asked Dr Barrell to ensure that the WIGOS Editorial Board included the requirements for GCW regulatory and guidance material in its activities.
- A37 CBS-MG requested the OPAG DPFS to consider nominating experts to participate in the GCW Working Structure, and in particular in the Integrated Products Working Group.
- A38 CBS-MG requested Dr Barrell, in her role as a member of the GCW Steering Group, with the assistance of OPAG IOS to provide guidance and assistance to the GCW regarding provision of WIGOS metadata concerning GCW Sites to the OSCAR/Surface.
- A39 CBS-MG asked the WIGOS project manager to convey to ICG-WIGOS its request that ICG-WIGOS and its task team on WIGOS metadata consider the requirements of CryoNet when developing the WIGOS metadata standard.
- A40 CBS-MG requested Mr Charpentier to coordinate PHORS community description of the problems being experienced with real-time distribution of AntON reports in table driven code forms and to pass this to the chair of OPAG ISS.
- A41 CBS-MG requested the chair of OPAG ISS to provide assistance to the PHORS community in resolving the issues identified in the report to be collated by Mr Charpentier on real time distribution of AntON reports in table driven code form.
- A42 The Group requested the Chair of OPAG PWS (Mr Fleming) to lead a CBS review of the EC-PHORS Services White Paper, calling on assistance from other OPAGs as appropriate.
- A43 The Group requested the Secretariat (C/OSD) to provide input to CBS-16 by Sept. 2016 on the establishment of Polar Regional Climate Centres.

- A44 All OPAGs were asked to consider the elements coming from the YOPP (Year of Polar Prediction) summit that required a specific involvement from global centres and that could be considered by CBS-16 (Annex 12).
- A45 CBS-MG asked the WIGOS Project Office with an article on GCW for inclusion in the next issue of the WIGOS newsletter based on input from Mr Charpentier.
- A46 CBS-MG asked the WIGOS Project Manager to add all CBS Management Group members to the distribution list for the WIGOS newsletter.
- A47 CBS-MG requested the Secretariat (C/OSD) to organize side meetings on GCW at EC-68 and at CBS-16.
- A48 CBS-MG requested the OPAG IOS, through the IPET-OSDE, to assist GCW in its activities, propose science questions, and investigate impact of in situ observations in high elevation mountain over 4000m-5000m on NWP, climate monitoring and services, and other Application Areas.
- A49 CBS-MG asked its President to invite CIMO to collaborate with the OPAG IOS on operational aspects associated with the implementation of observing stations in high mountain regions.
- A50 CBS-MG asked its President to invite the GCW to consider using the WIGOS Data Quality Monitoring System (WDQMS) to provide quality monitoring of CryoNet Sites/Station and GCW contributing stations, and in particular to use specialized WIGOS Regional Centres (WRCs).

## **5.6 Capacity development**

### **5.6.1 OPAG IOS**

136. CBS Management Group noted the briefing on capacity development by OPAG IOS and OPAG ISS (document [D18-1](#)).
- D45 CBS-MG requested that Members and satellite operators in CGMS should continue to provide sufficient support to the VLab (training centres of excellence, technical support function) to enable the VLab fulfil the expectations and put into practice the new VLab Strategy 2015-2019.
137. CBS-MG noted that ICG-WIGOS was intending to increase capacity development activities as part of the pre-operational phase, and would welcome any collaboration on the development of e-learning tools.

### **5.6.2 OPAG ISS**

138. CBS-MG concurred that improving national and regional ICT infrastructure was a major challenge that could not be met by CBS, and that strong leadership was needed from the Regional Implementation Teams set up by the Regional Associations, although expertise from CBS experts might be needed to support these.

### **5.6.3 OPAG DPFS**

## **Severe Weather Forecasting Demonstration Project (SWFDP)**

139. CBS Management Group noted the briefing on capacity development by OPAG DPFS (document [D18-3](#)).
- D46 CBS-MG agreed to use the CBS Session and other channels to advocate for voluntary contributions by Members and donor agencies toward implementation of capacity development mechanisms (especially SWFDP) that assist Members in developing countries and LDCs to develop and deliver high quality.

### **5.6.3 OPAG PWS**

140. CBS-MG reviewed the information regarding capacity development in PWS in document [D18-2](#) and its Annex [D18-2A](#). It appreciated that capacity building in PWS was both resource and time intensive.
- D47 CBS-MG proposed that CBS requested Members to volunteer experts with skills to assist with capacity development in the areas of impact-based forecasting and risk-based warning, and in application of new technology to service delivery.

## **5.7 Governance**

### **5.7.1 Governance of Manuals and Guides**

141. CBS-MG noted the contents of [document D19](#) on CBS contributions to WMO governance. These covered improvements to the approvals procedures for amendments to Technical Regulations, repeat audits of WIS centres starting from 2016, and World Weather Watch quantitative and qualitative monitoring that was to be replaced by more comprehensive WIGOS monitoring of observations. CBS-MG noted that the WIS audit process, the audit procedures being implemented by the amendments to the Manual on GDPFS and the inclusion of feedback mechanisms in the WIGOS monitoring would all contribute to quality improvement by encouraging responses to deficiencies found by the audit and monitoring processes

### **5.7.2 Review of Technical Regulations - Outcome of PTC-2016**

142. CBS-MG noted the summary of the outcomes of PTC-2016 discussions on Technical Regulations in [document D29](#) and its [appendix D29-A](#). *[Note: the document on Technical Regulations presented to PTC-2016 was available from: [https://drive.google.com/a/wmo.int/file/d/0B1MKEzYs7u\\_-aOVtR1VJN212dW8/view?usp=drivesdk](https://drive.google.com/a/wmo.int/file/d/0B1MKEzYs7u_-aOVtR1VJN212dW8/view?usp=drivesdk)]*
143. CBS-MG noted that all Technical Regulations were expected to be reviewed by Cg-18. (See [Annex 11](#)).
- D48 CBS-MG recommended that it should retain authority to approve the content of Guides, and that it should retain the ability to operate procedures that did not rely on discussion at a full session of the Commission for aspects of the guides.
- A51 CBS-MG agreed to plan a briefing on Technical Regulations at CBS-16, probably as a TECO Focus session.
- A52 CBS-MG agreed that CBS-16 would agree a plan for the revision of the Manuals and Guides for which it was responsible that would deliver updated material before Cg-18, ready for assessment at the CBS session following Cg-18.
- D49 CBS-MG recommended that the CBS OPAG PWS should be given responsibility for developing the regulations and guidance on service delivery.
- A53 CBS-MG requested WMO Secretariat to provide the Content Management System to support publication of Technical Regulations rapidly so that the revision of Technical Regulations could be compatible with it.

## 6. JOINT WORKING

### 6.1. Joint working arrangements with WMO bodies

#### 6.1.1 *Inter-programme Expert Team on Climate Data Modernisation Programme IPET-CDMP*

144. CBS-MG noted the briefing on the work of IPET-CDMP of CCI and of which Mr dell'Acqua was co-chair (representing CBS). The aim of the group was to develop an auditable framework for data management globally to ensure quality, long term accessibility, integrity and availability of the data needed to support climate services (See [document D25](#)).

A54 CBS-MG asked the chair of OPAG ISS to include the Technical Reference document on High Quality Global Data Management Framework for Climate (HQ-CDMFC) being developed by IPET-CDMSP in its considerations when developing Part C of the WIS.

D50 CBS-MG decided to include the HQ-CDMFC and the work of ET-CDMP in its discussions on WIS Part C at CBS-16.

A55 CBS-MG noted that not only was agreeing definitions important, but it was also important to ensure that a common vocabulary was used. It asked ET-CDMP to consult with IPET-DRMM on its proposed names to avoid giving different concepts the same name or the same concept different names.

#### 6.1.2 *CBS-CAeM collaboration on space weather*

145. CBS-MG noted the briefing material in [document D30](#) that included a summary of the requests from CG-17 for CBS and CAeM to address topics associated with Space Weather according to the draft four year plan [annexed to Resolution 38 \(Cg-17\)](#). It also noted the progress made since Cg-17.

146. No change was proposed to the activities foreseen in the draft four-year plan.

147. Following the consultation of the Presidents of CAeM and CBS in January 2015, the proposed working structure included an Inter-Programme Team on Space Weather Information, Systems and Services (IPT-SWISS) reporting in parallel to CAEM and CBS. Draft Terms of reference for this team are included in [Annex 6](#). The IPT-SWISS would nominate experts among its members to participate in the relevant groups of other WMO Technical Commissions, and would maintain points of contacts with the various Regional Associations.

148. CAeM and CBS needed to agree a coordinated mechanism to provide joint oversight of IPT-SWISS. In particular, CAeM and CBS needed to agree on the number of experts composing the team and on the nomination of a Chair and Co-Chair. It was proposed that the details of management procedures were not included in four-year plan in order to allow CAeM and CBS to make adjustments when necessary.

149. Mr Branski noted that space weather services were being provided by some NMHS and that they served both international civil aviation and other application areas. He noted that space weather services were still in their infancy and cross-OPAG coordination may be needed.

D51 CBS-MG considered options for accommodating IPT-SWISS in its management structure and concluded that the team would report to OPAG DPFS. This was because CBS-MG expected that the group would move rapidly from considering observations into guiding services development.

A56 CBS-MG agreed that editorial updates should be made to the four year plan of IPT-SWISS:

- The terms and definitions of space weather should be updated in accordance with the

outcome of the terminology task team;

- At the end of Chapter 4.2, the target dates for the last meeting of ICTSW and for establishing IPT-SWISS should be postponed by 6 months;
- In Chapter 4.3 the section dedicated to the partnership with ISES should be updated to reflect that the planned working arrangement is now implemented.

### **6.1.3 Space weather related terminology**

150. CBS-MG noted [document D31](#), and in particular that Resolution 38 (Cg-17) requested “CBS to re-examine the naming and the definitions of “space weather” and “space meteorology” in all official languages.
151. The proposed definition of “space weather” built on an earlier definition proposed by the European Union COST Action 724, with adjustments stemming from the discussion within the team. The team did not consider any change to the definition of “space meteorology” that was defined by WMO as “the use of satellites to observe atmospheric properties”, i.e. an equivalent to “satellite meteorology”.
152. There was a consensus on all terms and definitions with the exception of the term “meteorology of space” in English. Space weather experts had stressed that in English the discipline studying “space weather” was usually named “space weather” in their community, while the CBS representative and the Secretariat had argued that since the discipline studying “weather” was named “meteorology”, it would be semantically more consistent that the discipline studying “space weather” be named “meteorology of space”. This was however not seen as a critical issue. In order to provide comprehensive guidance to readers and translators, the team recommended that both expressions should be introduced in the glossary, with a note indicating the most common usage.
153. It was expected that providing these terms and definitions in all WMO official languages would facilitate mutual understanding and contribute to a greater awareness of space weather related matters in the meteorological community and in the United Nations system at large. The International Civil Aviation Organization and the International Telecommunications Union had already indicated their intention to use the WMO terminology when agreed. The proposed terms and definitions are included in [Annex 8](#).
- D52 CBS-MG recommended that WMO use the definitions and translations associated with space weather in [Annex 8](#).
- A57 CBS-MG asked the secretariat to inform other interested bodies of the definitions and their translations associated with space weather after they had been approved by EC.
- D53 CBS-MG recommended to EC-68 the draft resolution on the topic of space weather related activities in [Annex 7](#).

### **6.2. Joint working arrangements with Members**

154. CBS-MG noted the contents of [document D21](#), and in particular that key parts of the infrastructure supporting the services for which CBS was responsible were provided by Members. It also noted that these Members might not individually be able to fund the full capability that was required, so that additional funding mechanisms might need to be found.
155. CBS-MG expressed its strong appreciation for the contributions of Members for providing experts, resources and facilities in support of the work of CBS.

## **6.3 Joint working arrangements with other organizations including HMEI and the private sector**

### **6.3.1 Cooperation with HMEI**

156. Mr Karpov, Executive Secretary of HMEI, briefed CBS-MG on the association of Hydro-Meteorological Equipment Industry. The links between HMEI and WMO were: high-level consultative meeting (WMO President, SG/DSG, D/OBS, HMEI chair, HMEI secretariat); working agreement between secretariats (D/OBS is focal point); cooperation/coordination on the level of Technical Commissions and Expert Teams (nomination of HMEI experts, participation in expert teams). Six CBS expert teams included experts from HMEI.

157. Mr Branski noted that there had been a standing invitation to HMEI to participate in expert teams as an observer. Expert teams that needed input from industry should go through HMEI to ensure vendor neutrality.

### **6.3.2 Report of the coordinator on GEO and GEOSS activities related to WMO**

158. CBS-MG considered the report by the coordinator for GEO and GEOSS activities related to WMO ([document D34](#)). It appreciated the progress that had been made, and noted that there were effective interactions between OPAGs and GOESS activities.

159. CBS-MG recommended that OPAGs consider the GEOSS task "GEOSS development and GCI operations" when preparing their work plans. (See [http://earthobservations.org/geoss\\_wp.php](http://earthobservations.org/geoss_wp.php))

D54 CBS-MG identified the potential overlaps and synergies between WIS and the plans of GEOSS, but recommended that a clear distinction was made between the WMO systems and the GEO systems to retain the visibility of WMO infrastructure, to avoid duplication of existing systems by GEO, and to avoid reductions in investments in basic infrastructure required to deliver WMO services.

## **7 TOOLS TO ASSIST CBS ACTIVITIES**

### **7.1 Responsibility for managing manuals and guides**

160. CBS-MG noted [document D22](#) and that Seventeenth Congress extended the ability to use the "fast track" (now known as "simple") and "between sessions" (now known as "standard") procedures for amending Manuals and Guides to all Manuals and Guides managed by CBS. (See *Resolution 21, Cg-17, on page 274 of the English version of the Cg-17 report, based on Recommendation 15, CBS-Ext.(2014) on page 99 of the CBS Ext.(2014) report*)).

161. The procedures introduced by Resolution 21 (Cg-17) did not require the President of WMO to approve changes, unlike other change procedures for technical regulations.

162. Under the procedures, CBS had to nominate an OPAG to be responsible for each Manual and Guide, and for Expert Teams to be assigned to the maintenance of the components of those Manuals and Guides.

D55 Considering a request from the secretariat to provide additional guidance on the interpretation of the condition to permit a change to use the simple procedure, CBS Management Group considered that the most appropriate approach would be to designate as "technical specifications" those sections of Manuals and Guides that were anticipated being appropriate for the simple procedure.

D56 CBS Management Group decided that changes implemented using the simple procedure should be referred to the President of WMO for confirmation after completion of the simple

procedure documented in resolution 21 (Cg-17), recognizing the responsibility of the President of WMO to act on behalf of Executive Council between sessions.

- D57 CBS Management Group decided to allocate responsibility for managing the Manuals and Guides to the OPAGs and Expert Teams listed in Annex 10. The list includes a specification of which components of the Manuals and Guides should be considered to be technical specifications for the purpose of the simple change procedure.
- D58 CBS-MG recommended that ICG-WIGOS should decide whether to recommend that the simple and standard procedures could be extended to WIGOS documentation.

## **7.2 Managing work flow to support CBS activities**

163. CBS-MG noted the briefing in [document D23](#) on the facilities to assist the work of its expert teams.
- D59 CBS management group considered the need for workflow management tools and strongly supported the requirement.
164. CBS management group appreciated the development of an extranet to provide additional capabilities, both for the experts working for the Commission and so that Members could see the work of the Commission.
- D60 CBS Management Group requested that material on the existing web site remained available at the existing locations for at least a year after introduction of the extranet.

## **8 CERTIFICATES OF RECOGNITION**

165. CBS-MG considered the information provided in [document D24](#).
- D61 CBS-MG decided that instead of using his/her in the certificates the text should be "in recognition of the contribution of <name>" to avoid gender issues, mistakes in preparation of the certificates, and to simplify production of the certificates.
- D62 CBS-MG asked the secretariat to investigate whether the names on the certificate could use the version in the language of the expert, and in any case to ensure that the correct name was used.
- D63 CBS-MG decided to issue certificates to experts that had contributed to the work of CBS between CBS-15 and CBS-16 using the same criteria as for those issued during CBS-15.
- A58 Chairs of each OPAG would prepare a list of nominations experts from their OPAGs who should be considered for being awarded an "outstanding" certificate, together with a brief citation to be written on the certificate. This list should be passed to the Secretariat by 1 May 2016.
- A59 Chairs of OPAGs would identify experts listed in their expert teams that had made contributions, so that certificates would not be given to those who did not participate.
- A60 The secretariat will provide to OPAG chairs the list of those receiving "outstanding" certificates at CBS-15.
- A61 President and vice-president of CBS would assess the nominations for "outstanding" certificates in consultation with the OPAG chairs, and pass the final recommendations to the secretariat by 1 July 2016.
- A62 The secretariat would arrange for the production of the certificates and delivering certificates to Permanent Representatives.
- A63 CBS Management Group asked OPAG chairs their progress reports for CBS-16 thank the Members for their support to operational centres.
166. CBS Management Group reminded OPAG chairs that if countries were mentioned in a report to CBS-16 about a project, all participating countries should be mentioned.

## 9 NEXT MEETING OF CBS-MG

D64 There would be a brief meeting for CBS-MG members starting on the morning of Sunday 20 November 2016 to make final preparations for CBS-16. There would also be a short meeting at the end of the last day of the CBS-16 session.

D65 CBS-MG agreed that it needed to meet annually. The first meeting should be in January or February 2017. Consideration should be given to scheduling the meeting to minimize the cost. Depending on the agenda, the meetings should be three days, but longer meetings may be needed in years of a CBS session.

167. In addition to the formal meetings, opportunities should be taken to hold informal meetings alongside EC and other sessions when several members were attending a meeting together, the other members joining by teleconference.

## 10 ANY OTHER BUSINESS

168. Item 17 on the draft EC-68 agenda referred to the Madrid+10 conference and the International Conference on Multi-Hazard Early Warning Systems. CBS would need to contribute to this.

169. The format of EC documentation was being changed, and would be used for subsequent sessions of constituent bodies. **Decisions** would record items with no budgetary implication; **resolutions** record decisions that have budgetary or regulatory impact, and **recommendations** record items that lie outside the delegation to the session.

D66 Membership of the Task Team on the Future GDPFS should be the same as the team that met in the week preceding CBS-MG-16.

## 11 CLOSURE OF THE MEETING

### 11.1 Review of actions

170. The actions were listed in the draft minutes posted to the meeting website as the meeting progressed.

### 11.2 Formal close of meeting

171. Mr Branski closed the meeting at 1602 on 19 February 2016.

## SUMMARY OF ACTIONS AND DECISIONS

### Actions

A1 Mr Branski asked the Secretariat to distribute the outcome of the EC WG SOP to CBS-MG members.

A2 The concept note on the TECO would be further developed. Members would be invited to offer papers; the wording used by CIMO inviting contributions to their TECO would be used. This would be coordinated by Mr Shi, who would be the secretariat lead in arrangements for the TECO.

A3 The announcement of the TECO would be sent with the CBS-16 announcement by the end of March.

A4 The future of the GDPFS, possibly including changes to the manual, should be allocated time in the main session, as part of the strategy discussion, as the discussion needed to be interpreted. This also needed to be discussed in the TECO.

A5 Mr Branski asked that the draft agenda be adjusted to show the order of discussion and the work plan should also be drafted.

A6 Mr Branski asked for future work plans to be developed in a standard format based on the OPAG IOS document presented to CBS-MG-16 (annex 1 of input document D03). Each task should have an identifier consisting of the team name and a sequential number. The headlines of these should be included in the documents submitted to CBS-16 as a link to a file held on the web that contained the in tabular form of the work plan (the file would not be modified following approval of the CBS report). Ongoing (version-controlled) copies should be published and maintained on the web.

A7 Mr Branski asked that the 2012-2016 work plans should be summarized in the CBS documents reporting progress. He asked for them to be translated if they were formally submitted to the CBS-16 session.

A8 CBS-MG asked each OPAG to present its structure to CBS-16 as an organogram in addition to the standard text representation, and that the full as well as abbreviated team names should be included. These organograms should use a consistent symbology and colour scheme and differentiate between teams and roles of individuals (derived from the DPFS design).

A9 Noting the gender distribution of experts in its teams, CBS Management Group urged Members to nominate female experts, and asked the secretariat to include this request in the letter inviting nominations of experts.

A10 CBS Management Group asked the secretariat to prepare for CBS-16 statistics on the gender distribution of team membership decided by CBS (Chairs, Core Members) and of the nominations by Members (that is a second set of statistics that included associate members), and to use both sets when reporting to EC WG SOP.

A11 CBS-MG asked each of the OPAGs to prepare by July 2016 a work plan for the period 2016-2020 for consideration by CBS-16, including capacity development.

A12 CBS-MG asked that the nomination form asked for a justification of the nomination to each group that was nominated. It encouraged an online nomination procedure.

A13 CBS Management Group asked OPAG chairs to develop work plans on the assumption that the budget approved by Cg-17 would be allocated.

A14 ICT-PWS should establish a Task Team to work closely with the ETR Programme to assist in the development of suitable material to support Members in the implementation of the "Competency Framework for PWS Forecasters and Advisors" as approved by Resolution 4 of Cg-17.

A15 CBS Management Group asked for the chair of the SG-GCW to be invited to the next meeting of the ICT-IOS in April 2016.

A16 CBS Management Group asked all OPAG chairs to complete the Terms of Reference for their OPAG teams. The terms of reference should include meeting the requirements for GFCS.

A17 OPAG chairs should provide their updated Terms of Reference, organograms and updates to the report of CBS-MG-16 by 14 March, acknowledging that some OPAGs would need to modify these following their ICT meetings.

A18 Documents for CBS-16 should be provided to the secretariat before 12 August.

A19 CBS-MG requested the ICT-IOS to discuss how the IPET-WIFI activities could be fully integrated in the ICG-WIGOS teams or other CBS expert teams after CBS-16 allowing the IPET-WIFI to be dissolved. Proposal should then be made to CBS-16.

A20 The Group requested the OPAG IOS Chair, Mr Jochen Dibbern, to review the current draft Terms of Reference of the weather radar coordination group in liaison with CIMO and the Secretariat, and to make a proposal on behalf of the CBS Management Group at the CIMO Management Group meeting (Offenbach, Germany, April 2016). Once the Terms of Reference had been agreed by both Management Groups (by correspondence as necessary), the membership would be proposed and the formation of the coordination group submitted to EC-68 for establishment in line with the requirements WMO Regulations 38, 39. CBS-16 and the next CIMO Session (2018) would then be invited to note establishment of the group, and possibly propose further changes to its Terms of Reference and membership.

A21 CBS-MG noted that CCI had already approved the text of the CDMS specification, and that CBS Ext.(2014) had asked that these specifications should be incorporated into the WIS documentation. CBS-MG asked ICT ISS to prepare text that incorporated the CDMS specifications in the WIS documentation.

A22 CBS-MG asked OPAG ISS to consider an appropriate procedure for future updating of the CDMS in the WIS regulations if required by CCI.

A23 CBS-MG asked ICT ISS to ensure that there was appropriate CCI representation on the task team addressing data management.

A24 CBS-MG asked the OPAG DPFS to accelerate the implementation of the mechanism approved by Cg-17 to strengthen operational centres, built upon the lessons learned through the Severe Weather Forecasting Demonstration Project.

A25 CBS-MG urged the Secretariat to explore opportunities for additional donor funding to support the ongoing development of individual SWFDP projects and the central support for training.

A26 CBS-MG requested the OPAG DPFS to liaise with the relevant Regional Associations to identify regional entities that would support the SWFDP project beyond its operational phase.

A27 CBS-MG asked the ICT-PWS to provide some clear and realistic guidance as to which of the identified work items should be prioritised and to propose the resulting work plan to CBS-16.

A28 Mr Branski asked the DRR Programme to extract from the WMO Disaster Risk Reduction roadmap those deliverables required from CBS.

A29 CBS-MG asked all its OPAGs to include requirements stemming from the Sendai Framework and the WMO Disaster Risk Reduction roadmap when developing their Work Plans for presentation at CBS-16.

A30 CBS Management Group noted that the DRR roadmap provided tangible requirements that CBS could address, and suggested that the Director of the GFCS Office might provide similar guidance to Technical Commissions on GFCS requirements.

A31 CBS-MG asked ICT-IOS to plan for the termination of IPET-WIFI at its meeting ICT-IOS-9 in April 2016.

- A32 CBS Management Group Members should pass any further thoughts on big data to Mr Branski.
- A33 The input would be used to draft a CBS essay within two weeks of the end of the meeting.
- A34 Mr Branski would remind other Commissions of what had been asked of them.
- A35 CBS Management Group asked OPAG ISS to ensure that the replacement of TAC by IWXXM was coordinated with developments on WMO systems so that there was no loss of information to production systems.
- A36 CBS-MG asked Dr Barrell to ensure that the WIGOS Editorial Board included the requirements for GCW regulatory and guidance material in its activities.
- A37 CBS-MG requested the OPAG DPFS to consider nominating experts to participate in the GCW Working Structure, and in particular in the Integrated Products Working Group.
- A38 CBS-MG requested Dr Barrell, in her role as a member of the GCW Steering Group, with the assistance of OPAG IOS to provide guidance and assistance to the GCW regarding provision of WIGOS metadata concerning GCW Sites to the OSCAR/Surface.
- A39 CBS-MG asked the WIGOS project manager to convey to ICG-WIGOS its request that ICG-WIGOS and its task team on WIGOS metadata consider the requirements of CryoNet when developing the WIGOS metadata standard.
- A40 CBS-MG requested Mr Charpentier to coordinate PHORS community description of the problems being experienced with real-time distribution of AntON reports in table driven code forms and to pass this to the chair of OPAG ISS.
- A41 CBS-MG requested the chair of OPAG ISS to provide assistance to the PHORS community in resolving the issues identified in the report to be collated by Mr Charpentier on real time distribution of AntON reports in table driven code form.
- A42 The Group requested the Chair of OPAG PWS (Mr Fleming) to lead a CBS review of the EC-PHORS Services White Paper, calling on assistance from other OPAGs as appropriate.
- A43 The Group requested the Secretariat (C/OSD) to provide input to CBS-16 by Sept. 2016 on the establishment of Polar Regional Climate Centres.
- A44 All OPAGs were asked to consider the elements coming from the YOPP (Year of Polar Prediction) summit that required a specific involvement from global centres and that could be considered by CBS-16 (Annex 12).
- A45 CBS-MG asked the WIGOS Project Office with an article on GCW for inclusion in the next issue of the WIGOS newsletter based on input from Mr Charpentier.
- A46 CBS-MG asked the WIGOS Project Manager to add all CBS Management Group members to the distribution list for the WIGOS newsletter.
- A47 CBS-MG requested the Secretariat (C/OSD) to organize side meetings on GCW at EC-68 and at CBS-16.
- A48 CBS-MG requested the OPAG IOS, through the IPET-OSDE, to assist GCW in its activities, propose science questions, and investigate impact of in situ observations in high elevation mountain over 4000m-5000m on NWP, climate monitoring and services, and other Application Areas.
- A49 CBS-MG asked its President to invite CIMO to collaborate with the OPAG IOS on operational aspects associated with the implementation of observing stations in high mountain regions.
- A50 CBS-MG asked its President to invite the GCW to consider using the WIGOS Data Quality Monitoring System (WDQMS) to provide quality monitoring of CryoNet Sites/Station and GCW contributing stations, and in particular to use specialized WIGOS Regional Centres (WRCs).

A51 CBS-MG agreed to plan a briefing on Technical Regulations at CBS-16, probably as a TECO Focus session.

A52 CBS-MG agreed that CBS-16 would agree a plan for the revision of the Manuals and Guides for which it was responsible that would deliver updated material before Cg-18, ready for assessment at the CBS session following Cg-18.

A53 CBS-MG requested WMO Secretariat to provide the Content Management System to support publication of Technical Regulations rapidly so that the revision of Technical Regulations could be compatible with it.

A54 CBS-MG asked the chair of OPAG ISS to include the Technical Reference document on High Quality Global Data Management Framework for Climate (HQ-CDMFC) being developed by IPET-CDMSP in its considerations when developing Part C of the WIS.

A55 CBS-MG noted that not only was agreeing definitions important, but it was also important to ensure that a common vocabulary was used. It asked ET-CDMP to consult with IPET-DRMM on its proposed names to avoid giving different concepts the same name or the same concept different names.

A56 CBS-MG agreed that editorial updates should be made to the four year plan of IPT-SWISS: - The terms and definitions of space weather should be updated in accordance with the outcome of the terminology task team; - At the end of Chapter 4.2, the target dates for the last meeting of ICTSW and for establishing IPT-SWISS should be postponed by 6 months; - In Chapter 4.3 the section dedicated to the partnership with ISES should be updated to reflect that the planned working arrangement is now implemented.

A57 CBS-MG asked the secretariat to inform other interested bodies of the definitions and their translations associated with space weather after they had been approved by EC.

A58 Chairs of each OPAG would prepare a list of nominations experts from their OPAGs who should be considered for being awarded an "outstanding" certificate, together with a brief citation to be written on the certificate. This list should be passed to the Secretariat by 1 May 2016.

A59 Chairs of OPAGs would identify experts listed in their expert teams that had made contributions, so that certificates would not be given to those who did not participate.

A60 The secretariat will provide to OPAG chairs the list of those receiving "outstanding" certificates at CBS-15.

A61 President and vice-president of CBS would assess the nominations for "outstanding" certificates in consultation with the OPAG chairs, and pass the final recommendations to the secretariat by 1 July 2016.

A62 The secretariat would arrange for the production of the certificates and delivering certificates to Permanent Representatives.

A63 CBS Management Group asked OPAG chairs their progress reports for CBS-16 thank the Members for their support to operational centres.

## **Decisions**

D1 CBS Management Group decided that a 2-day TECO would be held during the two days before the CBS-16 session.

D2 CBS Management Group decided that the topic of the Technical Conference would be "Emerging Trends in Information and its Use".

D3 Five lunchtime TECO Focus sessions would be planned. There would be one for each OPAG. Reaching a conclusion on the topic of the fifth would be coordinated by Dr Barrell.

D4 The draft agenda for CBS-16 at Annex 3 was adopted. The sequence of agenda items should follow the running order as far as possible, and the strategic item should appear after the changes to technical regulations. Guidance on the detailed topics for the strategic discussion should be included in the annotated agenda.

D5 CBS Management Group noted that CBS-16 would need to include administrative decisions that were not required by CBS Ext.(2014), and therefore would require at least five days of discussion, as well as time to conduct the elections.

D6 CBS-MG concluded that the Terms of Reference for the Commission of Basic Systems in WMO No. 15 2012 Edition (Annex D07/1) included the requirement of Resolution 25 (Cg-17) for CBS to lead on managing changes to the Manual on WIGOS.

D7 CBS-MG recommended that the Terms of Reference for the Commission for Basic Systems adequately covered the data management aspects of "Part C" of the WIS.

D8 CBS-MG discussed item (g) in the terms of reference of CBS (GDPFS) and whether it captured the role of the GDPFS or duplicated items (k) and (l). CBS-MG concluded that item (g) remained appropriate.

D9 CBS-MG recommended that the OPAG structure still met the requirements of the CBS.

D10 CBS-MG recommended that the composition of the CBS-MG should be that shown in Table 1 of the Final Report of CBS-MG-16.

D11 CBS-MG decided to propose to CBS-16 the continuation of the role on CBS MG of a CBS DRR coordinator with the adding responsibility for capacity development related to disaster risk reduction to the terms of reference agreed by CBS-15.

D12 CBS-MG decided not to continue the role of CBS Capacity Development coordinator and to add capacity development coordination to the terms of reference of all OPAGs, and to add responsibility for capacity development to the terms of reference of the coordinator on Disaster Risk Reduction.

D13 CBS-MG decided that it no longer required the role of CBS Group coordinator on GEO and GEOSS activities related to WMO.

D14 CBS-MG confirmed that the Task Team on migration of upper air reports to BUFR should continue until it had completed its tasks.

D15 CBS-MG decided that the SG-RFC should retain its relationship with and report to to OPAG IOS, but that it should also provide reports directly to CBS-MG.

D16 CBS-MG noted the political aspects of radio frequency issues, and decided that the Chair of SG-RFC should be an associate member of CBS-MG without voting rights.

D17 CBS-MG decided on the following standard nomenclature for its teams: *ITT*: Inter-Commission Task Team (where the responsibility is joint between Commissions; fixed life); *IPT*: Inter-Programme Team (where responsibility is joint between Commissions; no set life); *IPET*: Inter-Programme Expert Team (where the responsibility is primarily CBS); *ET*: Expert Team; *TT*: Task Team (a team under an OPAG authorized by President CBS); *Ad hoc Task Team*: short-lived team for specific task authorized within an OPAG; *Coordinator*: individual with defined responsibilities; *Representative*: individual responsible for acting on behalf of another body; *Focal Point*: national, Commission or Programme coordination role.

D18 CBS-MG confirmed the process of accepting all nominations as "associate members" of teams and selecting "core members" from these. Although all members of expert teams would be invited to meetings, normally only core members would be offered financial support to attend meetings. It was essential that the associate members were included in the discussions of expert teams.

D19 The name of the OPAG on Public Weather Services should be changed to the "OPAG on Public Weather Services Delivery (OPAG PWSD)".

D20 The structure of the OPAG should move towards the establishment of transient Task Teams (TTs) that would be focused on specific, time-bound, objectives.

D21 The areas of Communications, Competency Assessment, Service Delivery and Quality Management were fundamental enablers to the work of the OPAG, and that any Task Teams formed to address these areas would report directly to the ICT-PWSD.

D22 Chairs and co-chairs of Expert Teams, and of those Task Teams reporting directly to ICT PWSD at the time, would be members of ICT PWSD.

D23 The previous Expert Team on Communication, Outreach and Public Education (ET-COPE) would be dissolved and its responsibilities transferred to the ICT, and would then be devolved to specific Task Teams as would be established to address particular issues.

D24 The previous Expert Team on Meeting User Needs in Reducing the Impact of Hydro-Meteorological Hazards (ET-DPM) should be re-named ET-IMPACT. That Expert Team should take over the responsibilities of the "Impact Advisory Group".

D25 The previous Expert Team on Services and Products Improvement and (ET-SPII) would be retained to assist Members with the application of technological developments to the effective delivery of public weather services.

D26 ET-SPII should work in close collaboration with the OPAG DPFS to facilitate the rapid and efficient application of new and emerging science and technology to improved service delivery.

D27 CBS Management Group recommended that there should be a Coordinator on Regional Association Liaison and a Coordinator on the Competency Framework on ICT PWSD.

D28 Terms of Reference for the two constituent Expert Teams within the proposed revised structure for the OPAG PWSD given in Annex 5 were agreed for recommendation to CBS-16.

D29 CBS Management Group recommended the structure for OPAG DPFS teams (see Annex 5); the terms of reference were still under development.

D30 CBS Management Group decided that in the proposal to CBS-16: the Steering Group on the Future GDPFS should report directly to CBS management group; ET-OSPLS should be renamed IPET-OSPLS.

D31 CBS Management Group decided that the proposal to CBS-16 on the structure of OPAG IOS should be that in Annex 5. This had two less expert teams than during the period 2012-2016.

D32 CBS MG decided that the proposal to CBS-16 on the structure of OPAG ISS should be that in Annex 5. The IPETs should retain as IPETs, but their names should be shorter than those approved by CBS-15.

D33 Noting the recommendations in input document D09, CBS-MG recommended that the IPET-WIFI activities should be fully integrated in the ICG-WIGOS teams or other CBS expert teams after CBS-16 and the IPET-WIFI dissolved.

D34 CBS Management group agreed with the proposal by ICG-WIGOS-5 for the ICG-WIGOS subsidiary expert teams.

D35 CBS-MG recommended that a WMO weather radar coordination group should be established to take on the role of a coordination group for radar systems for the wider WIGOS and not just in support of the applications under the WWW. It should be formed as an Inter-programme Expert/Task Team under the authority of CIMO and CBS Management Groups and under leadership of the relevant OPAGs in the two TCs.

D36 CBS-MG ratified the decision by ICG-WIGOS-5 to establish a WIGOS Review Editorial Board to ensure harmonization and synchronization of all contributions to WIGOS regulatory material from different teams.

D37 CBS-MG agreed that the CDMS specifications would be considered in the process of developing Part C of the WIS.

D38 CBS Management Group considered and agreed the topics proposed by OPAG DPFS for discussion at CBS-16 contained in input document D11.

D39 CBS-MG recommended to EC-68 the establishment of an Inter-Commission Task Team to address Cg-17's decision to: standardize identifiers for cataloguing of weather, water, climate, space weather and other related environmental hazard and risk information for cataloguing extreme weather, water and climate events (Resolution 9 (Cg-17)).

D40 CBS-MG also recommended to the EC Working group on Disaster Risk Reduction that the DRR governance structure should be adapted to place more emphasis on delivery rather than advisory groups.

D41 The MG recommended to the Tropical Cyclones RSMCs/TCWCs Technical Coordination Meeting (TCM) that TCM should find a way to enhance and formalize its roles within the WMO governance structure. It also suggested to TCM that TCM assess the advantages and disadvantages the existing situation to help guide the decision on the way forward. Regardless of the decision, CBS would ensure that its activities supported the Tropical Cyclone Programme.

D42 CBS Management Group considered that developing the basic systems in support of GFCS was already included in the Terms of Reference for CBS, and that the Commission was well placed to lead in capacity development of the basic infrastructure.

D43 Noting the strong support from ICG-WIGOS-5 for the proposal, CBS-MG decided to terminate IPET-WIFI and to integrate its activities into ICG-WIGOS and its task teams with strong involvement of CBS experts.

D44 The Group concurred with the need for a CBS review of GCW Regulatory and Guidance materials for inclusion in the WIGOS Manual and Guide respectively. Those materials should be submitted by the GCW Steering Group; the review would be coordinated by the WIGOS Editorial Board (with assistance from OPAGs and CCI as appropriate).

D45 CBS-MG requested that Members and satellite operators in CGMS should continue to provide sufficient support to the VLab (training centres of excellence, technical support function) to enable the VLab fulfil the expectations and put into practice the new VLab Strategy 2015-2019.

D46 CBS-MG agreed to use the CBS Session and other channels to advocate for voluntary contributions by Members and donor agencies toward implementation of capacity development mechanisms (especially SWFDP) that assist Members in developing countries and LDCs to develop and deliver high quality.

D47 CBS-MG proposed that CBS requested Members to volunteer experts with skills to assist with capacity development in the areas of impact-based forecasting and risk-based warning, and in application of new technology to service delivery.

D48 CBS-MG recommended that it should retain authority to approve the content of Guides, and that it should retain the ability to operate procedures that did not rely on discussion at a full session of the Commission for aspects of the guides.

D49 CBS-MG recommended that the CBS OPAG PWS should be given responsibility for developing the regulations and guidance on service delivery.

D50 CBS-MG decided to include the HQ-CDMFC and the work of ET-CDMP in its discussions on WIS Part C at CBS-16.

D51 CBS-MG considered options for accommodating IPT-SWISS in its management structure and concluded that the team would report to OPAG DPFS. This was because CBS-MG expected that the group would move rapidly from considering observations into guiding services development.

D52 CBS-MG recommended that WMO use the definitions and translations associated with space weather in Annex 8.

D53 CBS-MG recommended to EC-68 the draft resolution on the topic of space weather related activities in Annex 7.

D54 CBS-MG identified the potential overlaps and synergies between WIS and the plans of GEOSS, but recommended that a clear distinction was made between the WMO systems and the GEO systems to retain the visibility of WMO infrastructure, to avoid duplication of existing systems by GEO, and to avoid reductions in investments in basic infrastructure required to deliver WMO services.

D55 Considering a request from the secretariat to provide additional guidance on the interpretation of the condition to permit a change to use the simple procedure, CBS Management Group considered that the most appropriate approach would be to designate as "technical specifications" those sections of Manuals and Guides that were anticipated being appropriate for the simple procedure.

D56 CBS Management Group decided that changes implemented using the simple procedure should be referred to the President of WMO for confirmation after completion of the simple procedure documented in resolution 21 (Cg-17), recognizing the responsibility of the President of WMO to act on behalf of Executive Council between sessions.

D57 CBS Management Group decided to allocate responsibility for managing the Manuals and Guides to the OPAGs and Expert Teams listed in Annex 10. The list includes a specification of which components of the Manuals and Guides should be considered to be technical specifications for the purpose of the simple change procedure.

D58 CBS-MG recommended that ICG-WIGOS should decide whether to recommend that the simple and standard procedures could be extended to WIGOS documentation.

D59 CBS management group considered the need for workflow management tools and strongly supported the requirement.

D60 CBS Management Group requested that material on the existing web site remained available at the existing locations for at least a year after introduction of the extranet.

D61 CBS-MG decided that instead of using his/her in the certificates the text should be "in recognition of the contribution of <name>" to avoid gender issues, mistakes in preparation of the certificates, and to simplify production of the certificates.

D62 CBS-MG asked the secretariat to investigate whether the names on the certificate could use the version in the language of the expert, and in any case to ensure that the correct name was used.

D63 CBS-MG decided to issue certificates to experts that had contributed to the work of CBS between CBS-15 and CBS-16 using the same criteria as for those issued during CBS-15.

D64 There would be a brief meeting for CBS-MG members starting on the morning of Sunday 20 November 2016 to make final preparations for CBS-16. There would also be a short meeting at the end of the last day of the CBS-16 session.

D65 CBS-MG agreed that it needed to meet annually. The first meeting should be in January or February 2017. Consideration should be given to scheduling the meeting to minimize the cost. Depending on the agenda, the meetings should be three days, but longer meetings may be needed in years of a CBS session.

D66 Membership of the Task Team on the Future GDPFS should be the same as the team that met in the week preceding CBS-MG-16.

-----

**ANNEX 1: PARTICIPANTS**

**Fredrick BRANSKI**  
**(Chair)**  
**Proposed by: United States**

NOAA - National Weather Service  
1325 East-West Highway  
SILVER SPRING  
MD 20910  
United States of America  
Fax: +(1 301) 713 9450  
Tel: +(1 301) 713 3538, ext. 121  
Email: fred.branski@noaa.gov

**Susan BARRELL**  
**(Co-chair)**  
**Proposed by: Australia**

Bureau of Meteorology  
G.P.O. Box 1289  
3001 MELBOURNE  
VIC  
Australia  
Fax: +61 3 9669 4168  
Tel: +61 3 9669 4444  
Email: s.barrell@bom.gov.au

**Anthony REA**  
**(Core member)**  
**Proposed by: CBS**  
**Co-Chair OPAG IOS (By**  
**teleconference)**

Bureau of Meteorology  
G.P.O. Box 1289  
3001 MELBOURNE  
VIC  
Australia  
Fax: +61 3 9669 4548  
Tel: +61 3 9669 4222  
Email: a.rea@bom.gov.au

**Meiyan JIAO**  
**(Core member)**  
**Proposed by: China**  
**Co-chair OPAG PWS**

China Meteorological Administration  
46 Zhongguancun Nandajie  
100081 BEIJING  
China  
Fax: +86 10 6217 4797  
Tel: +86 10 6840 6662 / 6146  
Email: jiaomy@cma.gov.cn,  
guoji@cma.gov.cn

**Matteo DELL'ACQUA**  
**(Core member)**  
**Proposed by: France**  
**Chair OPAG ISS**

Météo-France  
42, avenue Gaspard Coriolis  
31057 TOULOUSE CEDEX  
France  
Fax: (+33) 5 6107 8109  
Tel: (+33) 5 6107 8124  
Email: matteo.dellacqua@meteo.fr

**Jochen DIBBERN**  
**(Core member)**  
**Proposed by: Germany**  
**Chair OPAG IOS**

Deutscher Wetterdienst  
Frankfurterstrasse 135  
D-63067 OFFENBACH  
Germany  
Fax: +49 69 8062 3836  
Tel: +49 69 8062 2824  
Email: jochen.dibbern@dwd.de

**Gerald FLEMING**  
(Core member)  
Proposed by: Ireland  
Chair OPAG PWS

Met Eireann  
30 Parkview  
WEXFORD  
Ireland  
Fax: +353 1 80 64 275  
Tel: +353 1 80 64 208  
Email: gerald.fleming@met.ie,  
gfleming@eircom.net

**Yuki HONDA**  
(Core member)  
Proposed by: Japan  
Co-chair OPAG DPFS

Japan Meteorological Agency (JMA)  
1-3-4 Otemachi, Chiyoda-ku  
100-8122 TOKYO  
Japan  
Fax: +81-3 3211 8407  
Tel: +81-3 3212 8341, ext.3332  
Email: honda.yuuki@met.kishou.go.jp

**Kenji TSUNODA**  
(Core member)  
Proposed by: Japan  
Co-chair OPAG ISS

Japan Meteorological Agency (JMA)  
1-3-4 Otemachi, Chiyoda-ku  
100-8122 TOKYO  
Japan  
Fax: +81-3 3211 8404  
Tel: +81-3 3212 8341 ext. 3177  
Email: tsunoda@met.kishou.go.jp

**Ken MYLNE**  
(Core member)  
Proposed by: United Kingdom  
Chair OPAG DPFS

Met Office  
FitzRoy Road  
EX1 3PB EXETER  
Devon  
United Kingdom of Great Britain and  
Northern Ireland  
Fax: +44 1392 88 5681  
Tel: +44 1392 88 6070  
Mobile: +44 7753880511  
Email: ken.mylne@metoffice.gov.uk

**Michel JEAN**  
(Coordinator)  
Proposed by: Canada  
DRR Coordinator

Meteorological Service of Canada  
Canadian Meteorological Centre  
2121 Route Transcanadienne  
H9P 1J3 Dorval  
Quebec  
Canada  
Fax: +1 514 421 4600  
Tel: +1 514 421 4601  
Email: michel.jean2@canada.ca

**James KONGOTI**  
(Coordinator)  
Proposed by: Kenya  
Capacity Building Coordinator

Kenya Meteorological Department (KMD)  
Dagoretti Corner  
Ngong Road  
P.O. Box 30259-00100  
NAIROBI  
Kenya  
Fax: +254 20 387 6955  
Tel: +254 20 386 7880-7  
Email: kongoti@meteo.go.ke

**Alexander GUSEV**  
(Coordinator)  
Proposed by: Russian Fed.  
GEO/GEOSS Coordinator

ROSHYDROMET  
12 Novovagankovsky Street  
123242 MOSCOW  
Russian Federation  
Fax: +7 96 800 33 339  
Tel: +7 484 396 8611  
Email: gusev\_ai@mail.ru

**Mingmei LI**  
(Interested expert)  
Proposed by: China  
Assistant to Ms Jiao

China Meteorological Administration  
46 Zhongguancun Nandajie  
100081 BEIJING  
China  
Fax: +86102174797  
Tel: +86 10 68406146  
Email: lmm@cma.gov.cn

**Tilman MOHR**  
(Interested expert)  
Proposed by: Germany

Else Sterne-Roth Str.8  
63075 OFFENBACH  
Germany  
Tel.: +49 6986 5333  
Email: Tilman.mohr@t-online.de

**David GRIMES**  
(President, WMO)

WMO Secretariat  
7 bis, Avenue de la Paix ,  
1211 Case Postale No. 2300 GENEVA 2  
Switzerland  
Email: dgrimes@wmo.int

**Petteri TAALAS**  
(Secretary-General)

WMO Secretariat  
7 bis, Avenue de la Paix ,  
1211 Case Postale No. 2300 GENEVA 2  
Switzerland  
Email: ptaalas@wmo.int

**Etienne CHARPENTIER**  
(Secretariat)  
Proposed by: WMO Secretariat

WMO Secretariat  
7 bis, Avenue de la Paix ,  
1211 Case Postale No. 2300 GENEVA 2  
Switzerland  
Fax: +41 22 730 8021  
Tel: +41 22 730 8223  
Email: echarpentier@wmo.int

**James DOURIS**  
(Secretariat)  
Proposed by: WMO Secretariat

WMO Secretariat  
7 bis, Avenue de la Paix ,  
1211 Case Postale No. 2300 GENEVA 2  
Switzerland  
Tel: +41 22 730 82 29  
Email: jdouris@wmo.int

**Anne-Claire FONTAN**  
(Secretariat)  
Proposed by: WMO Secretariat

WMO Secretariat  
7 bis, Avenue de la Paix ,  
1211 Case Postale No. 2300 GENEVA 2  
Switzerland  
Tel: +41 22 730 8151  
Email: acfontan@wmo.int

**Steve FOREMAN**  
**(Secretariat)**  
**Proposed by: WMO Secretariat**

World Meteorological Organization  
7 bis, avenue de la Paix  
Case postale No. 2300  
CH-1211 2 GENEVA  
Switzerland  
Fax: +41 22 730 8021  
Tel: +41 22 730 8171  
Email: sforeman@wmo.int

**Alasdair HAINSWORTH**  
**(Secretariat)**  
**Proposed by: WMO Secretariat**

WMO Secretariat  
7 bis, Avenue de la Paix ,  
1211 Case Postale No. 2300 GENEVA 2  
Switzerland  
Fax: N/A  
Tel: +41 22 730 8006  
Email: ahainsworth@wmo.int

**Abdoulaye HAROU**  
**(Secretariat)**  
**Proposed by: WMO Secretariat**

World Meteorological Organization  
7 bis, avenue de la Paix  
Case postale No. 2300  
CH-1211 2 GENEVA  
Switzerland  
Fax: +4 22 730 8021  
Tel: +41 22 730 8231  
Email: aharou@wmo.int

**Peer HECHLER**  
**(Secretariat)**  
**Proposed by: WMO Secretariat**

WMO Secretariat  
7 bis, Avenue de la Paix ,  
1211 Case Postale No. 2300 GENEVA 2  
Switzerland  
Tel: +41 22 730 8224  
Email: pechler@wmo.int

**Dimitar IVANOV**  
**(Secretariat)**  
**Proposed by: WMO Secretariat**

World Meteorological Organization  
7 bis, avenue de la Paix  
Case postale No. 2300  
CH-1211 2 GENEVA  
Switzerland  
Tel: +41 22 730 8283  
Email: divanov@wmo.int

**Haleh KOOTVAL**  
**(Secretariat)**  
**Proposed by: WMO Secretariat**

World Meteorological Organization  
7 bis, avenue de la Paix  
Case postale No. 2300  
CH-1211 2 GENEVA  
Switzerland  
Fax: +41 22 730 8021  
Tel: +41 22 730 8333  
Email: hkootval@wmo.int

**Jerome LAFEUILLE**  
**(Secretariat)**  
**Proposed by: WMO Secretariat**

WMO Secretariat  
7 bis, Avenue de la Paix ,  
1211 Case Postale No. 2300 GENEVA 2  
Switzerland  
Fax: +41 22 730 8021  
Tel: +41 22 730 8228  
Email: jlafeuille@wmo.int

**Dean LOCKETT**  
**(Secretariat)**  
**Proposed by: WMO Secretariat**

World Meteorological Organization  
7 bis, avenue de la Paix  
Case postale No. 2300  
CH-1211 2 GENEVA  
Switzerland  
Fax: +41-22-7308021  
Tel: +41-22-7308323  
Email: dlockett@wmo.int

**Filipe LUCIO**  
**(Secretariat)**  
**Proposed by: WMO Secretariat**

WMO Secretariat  
7 bis, Avenue de la Paix ,  
1211 Case Postale No. 2300 GENEVA 2  
Switzerland  
Tel: +41 22 730 8579  
Mobile: +41 79 305 98 80  
Email: flucio@wmo.int

**Filipe LUCIO**  
**(Secretariat)**  
**Proposed by: WMO Secretariat**

WMO Secretariat  
7 bis, Avenue de la Paix ,  
1211 Case Postale No. 2300 GENEVA 2  
Switzerland  
Tel: +41 22 730 8579  
Mobile: +41 79 305 98 80  
Email: flucio@wmo.int

**Samuel MUCHEMI**  
**(Secretariat)**  
**Proposed by: WMO Secretariat**

WMO Secretariat  
7 bis, Avenue de la Paix ,  
1211 Case Postale No. 2300 GENEVA 2  
Switzerland  
Tel: +41 22 730 8137  
Email: smuchemi@wmo.int

**Luis NUNES**  
**(Secretariat)**  
**Proposed by: WMO Secretariat**

Instituto de Meteorologia  
Rua C - Aeroporto de Lisboa  
1749-077 LISBOA  
Portugal  
Fax: +(351 21) 847 2370  
Tel: +(351 21) 844 7060  
Email: luis.nunes@meteo.pt

**Krunoslav PREMEC**  
**(Secretariat)**  
**Proposed by: WMO Secretariat**

World Meteorological Organization  
7 bis, avenue de la Paix  
Case postale No. 2300  
CH-1211 2 GENEVA  
Switzerland  
Tel: +41 22 730 8436  
Email: kpremec@wmo.int

**Lars Peter RIISHOJGAARD**  
**(Secretariat)**  
**Proposed by: WMO Secretariat**

World Meteorological Organization  
7 bis, avenue de la Paix  
Case postale No. 2300  
CH-1211 2 GENEVA  
Switzerland  
Fax: +41 22 730 8181  
Tel: +41 22 730 8193  
Mobile: +(1 443) 642 9182  
Email: lars.p.riishojgaard@nasa.gov

**Peiliang SHI**  
**(Secretariat)**  
**Proposed by: WMO Secretariat**

World Meteorological Organization  
7 bis, avenue de la Paix  
Case postale No. 2300  
CH-1211 2 GENEVA  
Switzerland  
Fax: (+41 -22) 730-8021  
Tel: (+41 -22) 730-8219  
Email: pshi@wmo.int

**Alice SOARES**  
**(Secretariat)**  
**Proposed by: WMO Secretariat**

WMO Secretariat  
7 bis, Avenue de la Paix ,  
1211 Case Postale No. 2300 GENEVA 2  
Switzerland  
Tel: +41 22 730 8449  
Email: asoares@wmo.int

**Xu TANG**  
**(Secretariat)**  
**Proposed by: WMO Secretariat**

World Meteorological Organization  
7 bis, avenue de la Paix  
Case postale No. 2300  
CH-1211 2 GENEVA  
Switzerland  
Fax: +41 22 730 8021  
Tel: +41 22 730 8264  
Email: xtang@wmo.int

**David THOMAS**  
**(Secretariat)**  
**Proposed by: WMO Secretariat**

World Meteorological Organization  
7 bis, avenue de la Paix  
Case postale No. 2300  
CH-1211 2 GENEVA  
Switzerland  
Fax: +41 (0) 22 730 8021  
Tel: +41 (0) 22 730 8241  
Mobile: +41 (0) 79 425 59 60  
Email: dthomas@wmo.int

**Igor ZAHUMENSKY**  
**(Secretariat)**  
**Proposed by: WMO Secretariat**

WMO Secretariat  
7 bis, Avenue de la Paix ,  
1211 Case Postale No. 2300 GENEVA 2  
Switzerland  
Tel: +41 22 730 8277  
Email: izahumensky@wmo.int

**Wenjian ZHANG**  
**(Secretariat)**  
**Proposed by: WMO Secretariat**

World Meteorological Organization  
7 bis, avenue de la Paix  
Case postale No. 2300  
CH-1211 2 GENEVA  
Switzerland  
Fax: +41 22 730 8021  
Tel: +41 22 730 8567  
Email: wzhang@wmo.int

## **ANNEX 2: AGENDA**

1. Organization of the meeting
  - 1.1. Welcome and objectives
  - 1.2. Adoption of the agenda
  - 1.3. Working arrangements
2. Organization of CBS-16
  - 2.1. Date and location of CBS-16
  - 2.2. Topic and timing of TECO
  - 2.3. Agenda topics and structure
  - 2.4. Review of the performance of CBS
3. Structure of CBS 2017-2021
  - 3.1. CBS Terms of Reference
  - 3.2. CBS Structure - OPAGs and Expert Teams
  - 3.3. Joint teams with other Commissions
4. Content of and responsibility for preparing documents for CBS-16 on priority topics
  - 4.1. OPAG IOS
  - 4.2. OPAG ISS
  - 4.3. OPAG DPFS
  - 4.4. OPAG PWS
5. Strengthening CBS Contributions to WMO Strategic Priorities
  - 5.1 Disaster Risk Reduction
  - 5.2 Global Framework for Climate Services
  - 5.3 WMO Integrated Global Observing System
  - 5.4 Aviation meteorological services
  - 5.5 Polar and high mountain regions
  - 5.6 Capacity development
  - 5.7 Governance
6. Joint working

6.1. Joint working arrangements with WMO bodies

6.2. Joint working arrangements with Members

6.3. Joint working arrangements with other organizations including HMEI and the private sector

7. Tools to assist CBS activities

7.1 Responsibility for managing manuals and guides

7.2 Managing work flow to support CBS activities

8. Certificates of recognition

9. Next meeting of CBS-MG

10. Any other business

11. Closure of the meeting

11.1. Review of actions

11.2. Formal close of meeting

## **ANNEX 3: AGENDA FOR CBS-16**

### **Option 4 – Strategic focus**

*Note: Items marked (\*) are required by Regulation 191*

#### **1 Opening of the session**

#### **2 Organization of the session**

- 2.1 Consideration of the report on credentials (\*)
- 2.2 Adoption of the agenda for the session
- 2.3 Establishment of committees (\*)

#### **3 Reports to the Commission**

*Note: the emphasis of this item is to establish the starting point for the decisions of the session – what has been delivered, and what remains to be delivered – and in the process to assess the performance of CBS*

- 3.1 Report by the President (\*)
- 3.2 Report by the Chair of OPAG IOS (\*)
- 3.3 Report by the Chair of OPAG ISS (\*)
- 3.4 Report by the Chair of OPAG DPFS (\*)
- 3.5 Report by the Chair of OPAG PWS (\*)
- 3.6 Report by the Rapporteur on GEOSS (\*)
- 3.7 Report by the Disaster Risk Reduction Coordinator (\*)
- 3.8 Report by the Capacity Building Coordinator (\*)

#### **4 Meeting strategic requirements for integrated service delivery and for integrated systems for observing, data processing, forecasting, telecommunications and data management**

*Note: the underlined phrase is extracted from the Terms of Reference for CBS. The aim of this agenda item is to decide on a strategic framework to guide the detailed work plans of CBS. It would be useful for the TECO to develop the concepts to support this agenda item*

4.1 Review of decisions of Seventeenth Congress and the Executive Council related to the Commission and the requirements of WMO President (\*), Members (\*), the technical commissions (\*), regional associations (\*) and the United Nations (\*), including those related to the WMO Strategic Plan (2016-2019) (\*) and WMO Operating Plan, the Global Framework for Climate Services (GFCS) and other priorities.

*Note: this item reports on the decisions already made*

4.2 Review of strategic drivers impacting on the responsibilities of CBS.

*Note: this item will discuss both requirements of WMO members and external factors that will influence how those requirements might be met*

4.3 Development of strategy for integrated service delivery and supporting integrated systems. [Future GDPFS – WMO Analysis and Prediction System (WAPS), is a major thrust in this area closing out the integrated (and seamless) approach to all components of the WWW and extending support to all WMO programs per resolution 11 of Cg-17. Note, this must be presented in the context of the integrated approach to all systems and services managed by CBS and serving WMO and its Members]

[Add QMS – CBS strategy and commitment to incorporate QMS across its activities. Is this where we should place decision making / governance process issues? Note that discussion may feed into extraordinary session discussion added as Agenda item 6.9]

*Note: the outcome of this agenda item is likely to be a set of factors to be considered and a work plan to develop a strategy to address these.*

#### 4.4 Summary of TECO discussions

*Note: this assumes that the TECO will include discussion on topics such as Big Data that will inform decisions under agenda item 4; key issues identified during the TECO should be summarized to assist the discussion under 4.3. **Question: should we ask for information papers to accompany the presentations to TECO?***

### **5 Decisions related to Technical Regulations, associated Guides and guidance material**

[Although this item of the Agenda follows the strategic focus under item 4, the MG decided to put this after item 3, Reports to the Commission, because it primarily concerns closing out past actions/work of the Commission before we get into the forward looking strategic discussions. It also allows time to bring forward points to Agenda item 4 that may have arisen from the TECO discussions, Agenda item 9. Note. This may mean these items come before some lunchtime TECO focus sessions. We may want to reconsider the order of some particular items with this in mind.]

[Should we just renumber Agenda items 4 and 5?]

*Note: this agenda item concentrates on recommending changes to Manuals and Guides. Background information should be limited to that essential to explain the context of the proposals and to demonstrate that they are sound.*

5.1 Recommendations for WMO-No.1160 Manual on the WMO Integrated Observing System and on WMO-No. ?? Guide to the WMO Integrated Observing System

5.2 Recommendations for WMO-No. 544 Manual on the Global Observing System and on WMO-No 488 Guide to the Global Observing System 5.3 Recommendations for WMO-No. 306 Manual on Codes

5.4 Recommendations for WMO-No 1060 Manual on the WMO Information System and WMO-No 1061 Guide to the WMO Information System and supporting guides

5.5 Recommendations for WMO-No 386 Manual on the Global Telecommunications System

5.6 Recommendations on WMO-No.485 Manual on the Global Data-Processing and Forecasting System and on WMO-No. 305 Guide on the Global Data-processing System

5.7 Recommendations on WMO-No. 834 Guide to Public Weather Services

### **6 Decisions on the work plan for the Commission (\*)**

*Note: this should concentrate on setting the work plans for the CBS, its Management Group, coordinators and rapporteurs and its OPAGs for the period 2017-2020.*

6.1 Consideration of WMO organizational changes under consideration, i.e., outcomes from EC-SOP and EC

6.2 Decisions on the development of WIGOS and the Space Programme

6.3 Decisions on the development of WIS

6.4 Decisions on the development of the Global Data Processing System

6.5 Decisions on the development of the Public Weather Service

6.6 Decisions on CBS activities to support WMO Priority activities not managed by CBS, including Disaster Risk Reduction, the Global Framework on Climate Services,

6.7 Review of the Terms of Reference of the World Weather Watch Programme

6.8 Review of the Terms of Reference of the Commission for Basic Systems

6.9 CBS working structure

6.10 CBS Extraordinary consideration [CBS-MG discussion of this was under Agenda item 4 but perhaps this is better considered here in the work plan of the Commission and after the strategic discussions of Agenda item 4?]

**7 Review of previous resolutions and recommendations of the Commission and relevant Executive Council resolutions. (\*)**

*Note: this checks whether previous resolutions and recommendations should be retained, modified or withdrawn.*

**8 Election of Officers. (\*)**

*Note: election of the President and Vice-President*

**9 Report on the technical conference.**

*Note: this should concentrate on those aspects not covered under agenda item 4.2 and form the formal report of the technical conference*

**10 Other business.**

**11 Date and location of next meeting.**

**12 Closure of the session.**

#### **ANNEX 4: DRAFT TERMS OF REFERENCE FOR THE OPAGS OF CBS**

The following are draft Terms of Reference for the OPAGs of CBS.

##### **OPAG on Integrated Observing Systems**

- (a) To coordinate all activities related to the surface- and space-based components of the Global Observing System (GOS), which is a major component of the WMO Integrated Global Observing System (WIGOS), in particular the work of the expert, implementation/coordination and inter-programme expert teams and/or rapporteurs established by the Commission under the responsibility of the OPAG, and to liaise and cooperate with the other OPAGs, and regional association technical teams;
- (b) To inform Members and regional associations of scientific and technical developments on observing technology and techniques of the surface-based and space-based components of the GOS;
- (c) To evaluate and advise on the comprehensive observational data requirements of the World Weather Watch, the Global Framework for Climate Services and other WMO programmes and international programmes supported by WMO, and to recommend measures to meet those requirements, including coordination of recommendations concerning satellite services, related ground receiving systems and new satellite products;
- (d) To improve the utilization of satellite systems by providing guidance on the provision of data products and services from all observation systems, and by assessing the adequacy of related plans for implementation;
- (e) To review and advise on the design, implementation and evolution of WIGOS taking into account established requirements for data as well as cost, capabilities and performance of existing and new observing systems using information received from observing programmes, demonstrations and impact studies;
- (f) To review and coordinate monitoring relating to WIGOS and its component systems, including a level of progress against the Implementation Plan for the Evolution of Global Observing Systems and the extent of compliance with WMO regulatory material;
- (g) To update regulatory and guidance material on the GOS and make recommendations for amendments, in particular to achieve and sustain alignment to the emerging WIGOS regulatory material;
- (h) To publicize education and training material and events related to WIGOS;
- (i) To monitor progress of the implementation of the current WMO Strategic and Operating Plans on matters related to WIGOS and contribute to the development of the next Strategic and Operating Plans and the related strategic aims of the Commission;
- (j) To assure adequate exchange of information between WMO and satellite agencies including the participation in international satellite groups such as the Coordination Group for Meteorological Satellites and the Committee on Earth Observation Satellites;
- (k) To coordinate the WMO requirements for radio frequency bands and assignments of radio frequencies to meteorological telecommunications, instruments, sensors, both

for operational and research purposes and to liaise with the International Telecommunication Union on allocation matters;

- (l) To provide the technical lead, with the Commission for Instruments and Methods of Observation, and to contribute to the development and implementation planning of WIGOS and coordinate with the Inter-Commission Coordination Group on the WMO Integrated Global Observing System;
- (m) To develop contributions to the activities of the Disaster Risk Reduction Programme.

#### **OPAG on Information Systems and Services**

- (a) To coordinate all activities related to Information Systems and Services including telecommunications and data management, in particular the work of the expert and implementation/coordination teams and/or rapporteurs established by the Commission under the responsibility of the OPAG, and to liaise and cooperate with the other OPAGs, and regional association technical teams;
- (b) To inform Members and regional associations of all relevant developments and requirements relating to telecommunications, data management and the corresponding activities of the International Telecommunication Union and the International Organization for Standardization;
- (c) To monitor the operation of the WMO Information System (WIS), to assess the level of implementation of new telecommunication, database and data management techniques as they relate to WMO Programmes and other international organizations, and to make proposals regarding the organizational and planning aspects of WIS and the data management functions;
- (d) To plan the implementation of and make proposals on the organization, technical and operational aspects of WIS, specifically the Main Telecommunication Network, regional and sub-regional telecommunication networks, as well as meteorological data-collection and distribution systems via environmental observation and communications satellites;
- (e) To maintain the existing codes and data representation forms, and develop and implement, as required, data representation forms of meteorological information and products to meet new requirements including those of WMO Programmes and other international organizations;
- (f) To monitor progress towards, and take actions to implement, migration to table driven code forms;
- (g) To develop or adjust, as appropriate, meteorological data management functions including database specifications and monitoring the effectiveness of these functions;
- (h) To update regulatory and guidance material relating to telecommunications and data management;
- (i) To publicize education and training material and recommend training events on telecommunications and data management matters;
- (j) To monitor progress of the implementation of the current WMO Strategic and Operating Plans on matters related to telecommunications and data management, and contribute to the development of the next Strategic and Operating Plans and the related strategic aims of the Commission;

- (k) To lead the development and implementation planning for WIS taking into consideration the needs of WMO Programmes;
- (l) To contribute to the development and implementation planning of WIGOS and coordinate with the Executive Council Inter-Commission Coordination Group on the WMO Integrated Global Observing System;
- (m) To develop contributions to the activities of the Disaster Risk Reduction Programme and the Global Framework for Climate Services.

### **OPAG on Data Processing and Forecasting Systems**

- (a) To coordinate all activities related to the WMO Global Data-processing and Forecasting System (GDPFS), in particular the work of the expert and implementation/coordination teams and groups established by the Commission under the responsibility of the OPAG, and to liaise and cooperate with the other relevant working groups in order to take into consideration emerging requirements by other WMO Programmes;
- (b) To inform Members and regional associations of technical and scientific developments relating to the forecasting process, and to advise on the implementation of new techniques; and to coordinate organizational and planning aspects of the GDPFS including the requirements, procedures and practices for designating and maintaining GDPFS Centres;
- (c) To monitor the performance of the GDPFS and review compliance of its Centres against the designated criteria, which include, amongst others, standardized verification of numerical weather prediction (NWP) products, as part of the WMO Quality Management Framework;
- (d) To coordinate existing and new requirements stated by Members, and relevant United Nations agencies and international organizations for GDPFS products, and for the production of analysed and forecast data by the GDPFS Centres on all timescales;
- (e) To provide guidance on the integration of Ensemble Prediction Systems, high-resolution NWP, radar and satellite-based products into core operational forecasting, and on the use and interpretation of meteorological products made available by GDPFS Centres, in collaboration with the OPAG on Public Weather Services, the WMO Space Programme and the Commission for Atmospheric Sciences;
- (f) To guide the development, outputs and coordination of the operational production of sub-seasonal to longer-time scales, on the basis of the emerging requirements from Regional Climate Centres, Regional Climate Outlook Forums and National Meteorological and Hydrological Services, and in the context of Climate Services Information System of the Global Framework for Climate Services, in coordination with the Commission for Climatology and the Commission for Atmospheric Sciences;
- (g) To arrange for the provision of products and services by designated GDPFS Centres within the framework of the Emergency Response Activities (ERA) Programme, and advise on requirements for practical implementations of ERA operational systems and services, in coordination with the OPAG on Public Weather Services, and in cooperation with and support of relevant United Nations agencies and international organizations;
- (h) To coordinate, manage, guide, monitor and implement the Severe Weather Forecasting Demonstration Project (SWFDP) throughout all WMO Regions, in

coordination with the OPAG on Public Weather Services, and in liaison with other WMO Programmes as appropriate;

- (i) To develop and advise on education and training materials related to Data-processing and Forecasting System and recommend training events as appropriate;
- (j) To monitor progress on implementation of the current WMO Strategic and Operating Plans on matters related to the GDPFS and ERA programmes, and to contribute to the development of the next Strategic and Operating Plans and the related strategic aims of the Commission;
- (k) To contribute to the activities and work associated with the WMO five strategic high-priority areas, including:
  - (i) The Global Framework for Climate Services, disaster risk reduction, aviation meteorological services, and capacity development for developing and least developed countries;
  - (ii) Coordinating, collecting and conveying requirements for the Basic Systems, including WIGOS and WIS, for the production of GDPFS products, including for severe weather forecasting and warnings through the implementation of the SWFDP, in coordination with the OPAG on Public Weather Services Delivery.

#### **OPAG on Public Weather Service Delivery**

- (a) To coordinate all activities related to public weather services, in particular the work of the expert and implementation/coordination teams and/or rapporteurs established by the Commission under the responsibility of the OPAG, and to liaise and cooperate with the other CBS OPAGs, regional associations and technical commissions as required;
- (b) To integrate "The WMO Strategy for Service Delivery" and its Implementation Plan in the activities of the OPAG;
- (c) To coordinate the contribution of the OPAG to the WMO high-priority areas as relevant;
- (d) To assist Members, in coordination with other CBS OPAGs as appropriate, in the implementation of impact-based forecast and warning services;
- (e) To advise on the emerging requirements of the Public Weather Services community for tailored products generated by GDPFS Centres;
- (f) To assist NMHSs to strengthen their capabilities to ensure efficient and effective preparation and delivery of warning services through the national Public Weather Services programmes and channels by embedding multi-hazard, multi-scale early warning systems within an operational end-to-end service delivery framework;
- (g) To promote and support the education and training of the public and other users of NMHSs' products and services on their use and interpretation, including uncertainty information;
- (h) To inform Members and regional associations of, and evaluate, technical and scientific developments relating to the formulation, content, presentation and dissemination of weather information;

- (i) To provide guidance in the implementation of the PWS Competency Framework established by the Commission and approved by Congress;
- (j) To keep abreast of issues related to social and economic benefits of meteorological and hydrological services, considering that the socio-economic outcomes are the ultimate measure of effective service delivery to users;
- (k) To develop and provide to Members guidance material related to all aspects of public weather services;
- (l) To develop proposals for increasing the capabilities of Members as regards awareness, preparedness, prevention and response to weather-related disasters, including preparation of memorandums of understanding and standard operating procedures;
- (m) To develop proposals for the verification of end-user products, and evaluation of user satisfaction;
- (n) To improve procedures for the exchange of severe weather warnings between neighbouring countries;
- (o) To monitor progress on the implementation of the WMO Strategic and Operating Plans on matters related to the Public Weather Services Programme and contribute to the development of the next Strategic and Operating Plans and the related strategic aims of the Commission.

**ANNEX 5: DRAFT TERMS OF REFERENCE FOR EXPERT TEAMS WITHIN CBS**

Draft Terms of Reference for the teams within CBS OPAGs that were developed during the CBS-MG-16 meeting.

**OPAG IOS**

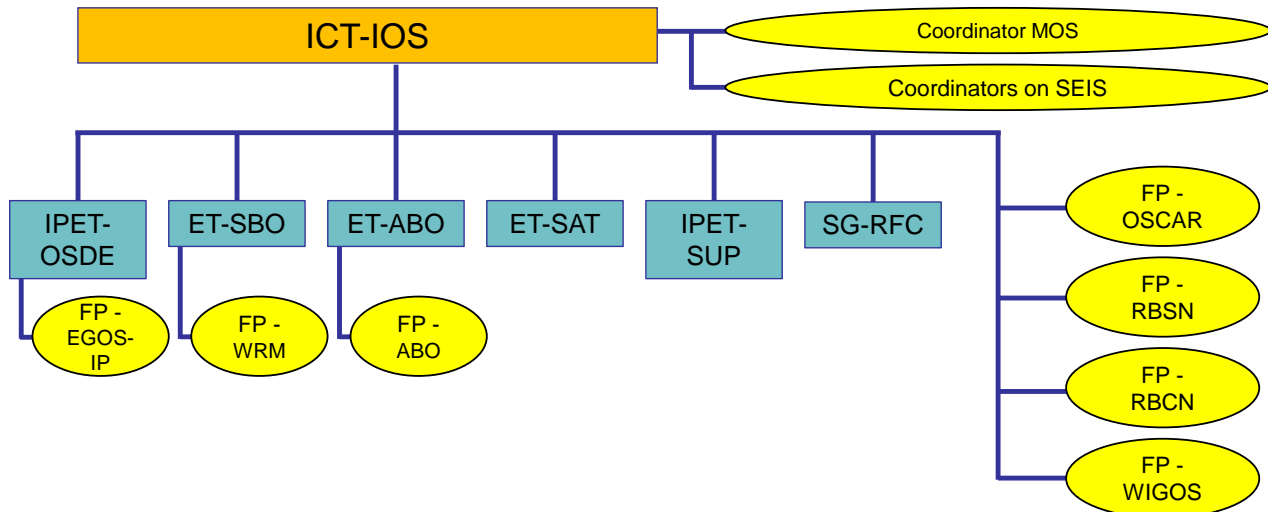

**IOS = Integrated Observing System**

- MOS = Marine Observing Systems
- SEIS = Scientific Evaluation of Impact Studies undertaken by NWP Centers
- OSDE = Observing System Design and Evolution
- EGOS-IP = Implementation Plan for the Evolution of the GOS
- SBO = Surface-Based Observing Systems
- WRM = Weather Radar Metadata
- ABO = Aircraft-Based Observing Systems
- SAT = Satellite Systems
- SUP = Satellite Utilization and Products
- RFC = Radio-Frequency Coordination
- OSCAR = Observing System Capabilities Analysis and Review resource
- RBSN = Regional Basic Synoptic Networks
- RBCN = GCOS and related Climatological matters
- WIGOS = WMO Integrated Global Observing System

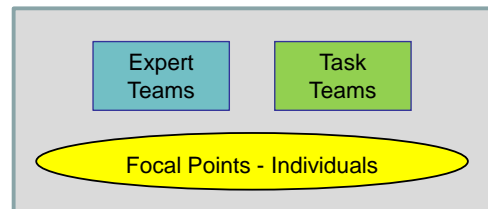

**Implementation-Coordination Team on Integrated Observing System (ICT-IOS)**

- (a) Contribute to the implementation of the WMO Integrated Global Observing System (WIGOS), in response to guidance from ICG-WIGOS and in coordination with other relevant WMO Programmes and TCs; Provide relevant advice and support to the president of CBS;
- (b) Coordinate the work of the OPAG-IOS Expert Teams, Inter-Programme Expert Teams, Steering Groups and Rapporteurs and report on results to the Commission for Basic Systems;
- (c) Monitor, report and make recommendations regarding the utilization of the composite observing systems under WIGOS and their capability to meet the requirements of all relevant WMO and co-sponsored programmes;
- (d) Review deficiencies in coverage and performance of the existing GOS; make proposals to improve the availability of data to meet stated requirements; monitor and report on progress in the evolution of the GOS;

- (e) Coordinate and consolidate the development of standardized high quality observing practices and prepare related recommendations, in contribution to the WIGOS Quality Data Monitoring System;
- (f) Assess the impacts of introducing new technology systems into the GOS on the status of regional observing networks, particularly those affecting the role of developing countries;
- (g) Consider and report on the issues of costing, joint funding and management of the GOS;
- (h) Contribute to strengthening the collaboration between CBS and the regional associations, by providing advice on possible solutions for newly identified requirements;
- (i) Coordinate the work of the Steering Group on Radio Frequency Coordination and report results, issues and provide recommendations regarding the work of this Group to the Commission for Basic Systems;
- (j) To coordinate as needed CBS observations implementation aspects of the GEOSS 10-Year Implementation Plan and advise the Management Group on activities that will contribute fully to the development and implementation of GEOSS, including enhanced operation of the World Weather Watch relevant to GEOSS;
- (k) To advise OPAG-IOS Expert Teams as needed with regard to Capacity Development Strategy and the WMO Programme for the Least Developed Countries;
- (l) Participate in the activities of the IPET on Coordination of Weather Radar Activities in collaboration with CIMO and other Technical Commissions as appropriate.

**Inter-Programme Expert Team on Observing System Design and Evolution (IPET-OSDE) (IPET-OSDE)**

- (a) Review and report on the observational data requirements of application areas within the scope of WIGOS;
- (b) Review and report on the capability of both surface-based and space-based systems that are components or candidate components of the evolving observing systems within the scope of WIGOS;
- (c) Carry out the rolling requirements review of application areas leading to Statements of Guidance concerning the extent to which present and planned observing systems meet user requirements for observations;
- (d) Review the implications of the Statements of Guidance concerning the strengths and deficiencies in the existing observing systems and evaluate the capabilities of new observing systems and possibilities for improvements and efficiencies;
- (e) Carry out impact studies of real and hypothetical changes to observing systems with the assistance of NWP centres;
- (f) Monitor and report progress against the new version of the Implementation Plan for Evolution of Global Observing Systems, based on the "Vision for the GOS in 2025"; identify new actions as necessary, taking into account developments within WIGOS, including those of the observations and monitoring pillar of the GFCS;

- (g) Promote activities which enhance progress against the Implementation Plan for Evolution of Global Observing Systems;
- (h) Propose updates to the “Vision for the GOS in 2025”, in response to evolving user requirements and observing system capabilities;
- (i) Propose guidance regarding observing system network design principles;
- (j) Prepare documents to assist Members, Technical Commissions, and Regional Associations, summarizing the results from the above activities;
- (k) Provide advice and support to the Chairperson of OPAG-IOS on development and implementation of WIGOS.

### **Expert Team on Surface-Based Observing Systems (ET-SBO)**

- (a) Contribute to the implementation of WIGOS by undertaking those tasks assigned to it by the OPAG IOS Chair as part of the WIGOS pre-operational phase priority activities;
- (b) Develop and update relevant elements of the WIGOS Regulatory and Guidance materials, including the Manual and the Guide to the GOS, with initial priority on weather radar and AWSs, and the WIGOS Quality Data Monitoring System;
- (c) Monitor and assess the status of planned and operational surface-based observing systems and ensure this is adequately described in Volume A and metadata database's of Members' observing system capabilities;
- (d) In collaboration with IPET-OSDE, assess the contribution of current and planned SBO systems to meeting user requirements for all Application Areas;
- (e) Facilitate the delivery of those EGOS-IP actions identified as priorities for OPAG-IOS;
- (f) Monitor the status of operational networks of SBO systems, promote best practice among WMO Members and provide advice on operational matters;
- (g) Assess the potential contribution of new and emerging SBO technologies in meeting the Vision for the GOS in 2025, in collaboration with CIMO;
- (h) To identify as appropriate the technical support required for project implementation plans, including guidance materials, technical specifications and project documentation for resource mobilization activities;
- (i) Provide advice and support to the Chairperson of OPAG-IOS on the implementation of the WIGOS framework and its operational aspects.

### **Expert Team on Satellite Systems (ET-SAT)**

- (a) Assess and document, in the framework of the WMO Rolling Review of Requirements, the actual and planned capabilities of operational and R&D satellites constituting the space-based component of WIGOS and their adequacy to meet the WMO requirements for satellite data and products. This will be achieved in considering the information provided by participating agencies as well as the outcome of the Coordination Group for Meteorological Satellites (CGMS) and

the Committee on Earth Observation Satellites (CEOS) , including e.g. the progress of CEOS constellations. The feedback from WMO should be communicated to CGMS and CEOS;

- (b) Provide technical advice with respect to both operational and R&D environmental satellites to assist in the implementation of integrated WMO-coordinated observing systems;
- (c) Assess progress of R&D and demonstration satellite systems, and identify opportunities and/or problem areas concerning satellite technology and plans;
- (d) Coordinate with IPET-SUP and other relevant CBS teams on satellite related matters

### **Inter-Programme Expert Team on Satellite Utilization and Products (IPET-SUP)**

- (a) Monitor the progress of satellite data availability and use by WMO Members, related issues and expectations, with the aim to publish findings and recommendations in a WMO document;
- (b) Provide advice and support to the development and implementation of WIGOS pre-operational phase, from a satellite user's perspective and coordinate with ET-SAT and IPET-OSDE on the evolution of the space-based component of Global Observing Systems;
- (c) Initiate and promote activities to improve the availability of operational and R&D satellite data according to user needs, monitor these activities in close coordination with the relevant working groups, regional associations and with WIS activities;
- (d) Review present and future R&D satellite data and products including their availability and potential applications, and provide advice with a view of increased utilization by WMO Members;
- (e) Review, and assist in addressing, the needs of WMO Members and regional associations for information regarding satellite capabilities and in particular access to and utilization of satellite data and products;
- (f) Promote development and harmonization of satellite data and products responding to WMO Members' needs, and develop and update relevant elements of the WIGOS Regulatory and Guidance materials, including the Manual and the Guide to the GOS, and the WIGOS Quality Data Monitoring System;
- (g) Keep under review the needs of WMO Members for training in satellite meteorology and related fields, and engage with the Management Group of the Virtual Laboratory for Education and Training in Satellite Meteorology (VLab) to address these needs, towards full utilization of satellite data from operational and R&D satellites, in accordance with the 2009–2013 Virtual Laboratory Training Strategy;
- (h) Holding joint and/or overlapping meetings with ET-SAT as appropriate, to facilitate interaction between users and providers of satellite systems, data and products;
- (i) Coordinate with ET-SAT with a view to making recommendations and receiving input on matters, such as the exchange, management, and archiving of satellite data and products, radio frequency utilization, as well as education and training and

other appropriate capacity-building measures related to the use of satellite data in all WMO Programmes, including support to resource mobilization activities;

- (j) Coordinate with WMO Technical Commissions and Programmes, including co-sponsored Programmes, activities related to satellite utilization and products, through ex-officio membership on the Team.

#### **Expert Team on Aircraft-Based Observing Systems (ET-ABO)**

- (a) Contribute to the implementation of WIGOS by undertaking those tasks assigned to it by the OPAG IOS Chair as part of the WIGOS pre-operational phase priority activities;
- (b) Manage the programme for the aircraft observing system and the budget for the corresponding expenditure of the AMDAR Trust Fund in line with its ToR;
- (c) Oversee the development and maintenance of the aircraft observations Quality Management System as a contribution to the WIGOS Data Quality Monitoring System;
- (d) Oversee the scientific and technical development and maintenance of the aircraft observing system;
- (e) Oversee and assist in the enhancement and optimization of the aircraft observing system in line with the requirements of Members and the recommendations and actions of the EGOS-IP;
- (f) Assist and provide support for training and outreach activities to support promotion and further development of the aircraft observing system; including identification as appropriate of the technical support required for project implementation plans, including guidance materials, technical specifications and project documentation for resource mobilization activities;
- (g) Provide advice and support to the Chairperson of OPAG-IO on the implementation of the WIGOS framework and its operational aspects.

#### **Steering Group on Radio-Frequency Coordination (SG-RFC)**

- (a) Keep under review allocations of radio frequency bands and frequency assignments of systems and applications for meteorological activities including their operational requirements (telecommunications, instruments, sensors, etc.) and research purposes, in close coordination with other technical commissions, especially CIMO, and the CBS/OPAG-ISS;
- (b) Coordinate with WMO Members, with the assistance of the WMO Secretariat, to:
  - (i) Ensure the availability of radio-frequency spectrum to meteorological and other environment monitoring radiocommunication services;
  - (ii) Ensure the proper notification and registration of frequency assignments used for meteorological purpose;

- (iii) Identify the future use of the radio-frequency spectrum for meteorological purpose;
- (c) Keep abreast of the activities of the Radiocommunication Sector of the International Telecommunication Union (ITU-R), and in particular of the Radiocommunication Study Groups, on radio frequency matters pertaining to meteorological activities, and represent WMO in ITU-R work;
- (d) Prepare and coordinate proposals and advice to WMO Members on radio regulation matters pertaining to meteorological activities with a view to ITU Radiocommunication Study Groups, radiocommunication Assemblies (RA), World Radiocommunication Conferences (WRC) and related global and regional preparatory meetings;
- (e) Facilitate the cooperation between WMO Members for the use of frequency bands allocated to meteorological and environment monitoring radiocommunication services with respect to:
  - (i) Coordination of radio-frequency spectrum use and frequency assignments between countries;
  - (ii) Sharing the same frequency bands between various radiocommunication services (e.g. meteorological aids and meteorological-satellite services (to provide compatibility between radiosondes and data collection platforms));
- (f) Facilitate the coordination of WMO frequency use activities with other international organizations which address radio spectrum management issues, including specialized organizations (e.g. CGMS, the Space Frequency Coordination Group (SFCG)) and regional telecommunication organizations, such as the European Conference of Postal and Telecommunications Administrations (CEPT), the Inter-American Telecommunication Commission (CITEL), the Asia-Pacific Telecommunity (APT), the Regional Commonwealth in the Field of Communications (RCC); the African Telecommunication Union (ATU), and the Arab Spectrum Management Group (ASMG);
- (g) Assist WMO Members, upon request, in coordination of frequency assignments of radiocommunication systems sharing a frequency band with meteorological radiocommunication systems in the ITU;
- (h) Increase the understanding of NMHS role in radio frequency coordination and the importance of the close collaboration with the ITU Radiocommunication Sector (ITU-R) and the Telecommunication Development Sector (ITU-D) in the accomplishment of the WMO priority activities, in particular GFCS, WIGOS and WIS.

#### **Coordinator on Marine Observing Systems (R-MAR)**

- (a) Collect information on the status of marine (i.e. marine meteorological and oceanographic) observations from the JCOMM approved sources;
- (b) Liaise with appropriate JCOMM Expert Teams, Groups, Observation Panels (DBCP, SOT, GLOSS), and associated Programmes (Argo, IOCCP, OceanSITES) to ensure that the actions from the EGOS-IP are being addressed and that JCOMM Implementation Goals are being considered by the OPAG IOS;
- (c) Provide input to the Chair of OPAG-IOS and Chair of IPET-OSDE on issues related to the implementation of marine observing systems, and their contribution to WIGOS pre-operational phase implementation;

- (d) Liaise with the RRR point of contact for Ocean Applications concerning user requirements and gap analysis;
- (e) Keep abreast of developments in marine observing systems and advise on coordinated assessment and implementation developments.

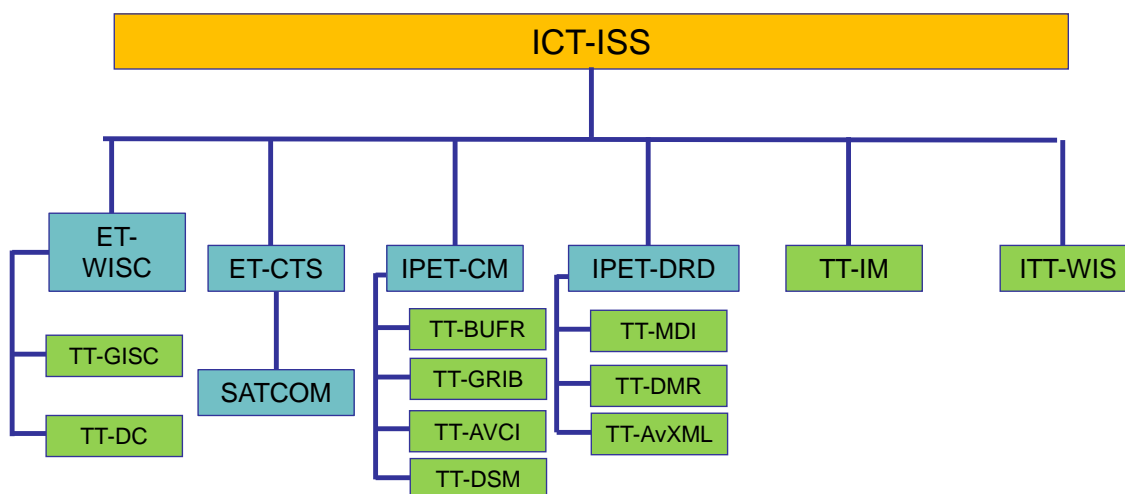
**OPAG ISS****ISS = Information Systems and Services**

WISC = WIS Centres

GISC = GISCs

DC = Data Centres

CTS = Communication Techniques and Systems

SATCOM = Satellite Communications

CM = Codes Maintenance

BUFR = BUFR

GRIB = GRIB

AVCI = Aviation Coding Issues

DSM = Data Standards Monitoring

DRD = Data Representation Development

MDI = Metadata Implementation

DMR = Data Modelling and Representation

AvXML = Aviation XML

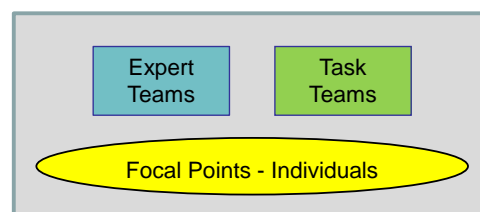
**Implementation Coordination Team for Information Systems and Services (ICT-ISS)**

- (a) Assess the implementation aspects at regional and global levels, including sustainability and necessary capacity-building, of the recommendations and proposals developed by the ISS teams;
- (b) Review and consolidate the recommendations and proposals developed by the ISS teams with a view to their submission to CBS;
- (c) Monitor, assess and take follow-up action on ISS requirements emerging from WMO Programmes and other international Programmes/projects, including cross-cutting activities such as GFCS, WIS/WIGOS, THORPEX and DRR;
- (d) Identify matters requiring the urgent consideration of the OPAG on ISS and develop proposals for tasks and organization of activities;
- (e) Advise the technical commissions on information management and data communications issues, especially in respect of the WIS and collaborate with technical commissions to develop and document appropriate standards and practices in information management;
- (f) Provide guidance for the ISS teams on requirements and priorities for development of the WIS.

- (g) Develop and maintain a strategic plan for the evolution of the WIS over a ten year forward looking period and explore and extend WIS functionality to build on new technology and applications.
- (h) Coordinate the work of OPAG ISS related to the implementation and evolution aspects of GEO and ICAO infrastructure, including maintenance of interoperability with GEOSS and SWIM to the benefit of Members,
- (f) Develop and maintain procedure for addressing security and incident management events with in WIS.

#### **Expert Team on WIS Centres (ET-WISC)**

- (a) Review and further develop the technical and operational specifications for the components and interfaces of WIS Centres and criteria for interoperability, certification and quality management of WIS Centres;
- (b) Maintain guidance and management procedures for the CBS demonstration and assessment capabilities of candidate GISC and DCPC centres in the framework of the GISC/DCPC demonstration procedure described in the Manual on WIS;
- (c) Review and develop the Manual on WIS (WMO-No 1060), the Guide to WIS (WMO No 1061) and associated informal guidance to better meet the needs of Members;
- (d) Maintain WIS competencies related to WIS centre operations and associated training and learning guides
- (e) Facilitate training on WIS by GISCs and RTCs
- (f) Review, further develop and oversee WIS monitoring activities, including those aspects of monitoring relating to the effectiveness of information exchange on behalf of the WWW and other Programmes, and take action to address issues that are identified by monitoring and auditing;
- (e) Review, develop and coordinate recommended practices and guidance on management of and access to operational information related to exchange of information through the WIS;
- (f) Provide coordination and collaboration mechanisms for supporting the implementation and operation of WIS centres;
- (g) Advise the technical commissions, regional associations and partner organizations on roles, responsibilities and implementation of WIS Centres;
- (h) Identify implementation and operational issues requiring the urgent consideration of the OPAG on ISS;
- (i) Review and support procedures for periodic assessment of the WIS centres.
- (j) Contribute to the implementation and evolution aspects of GEO and ICAO infrastructure, including maintenance of interoperability with GEOSS and SWIM to the benefit of Members.

### **Task Team on Data Centres (TT-DC)**

- (a) In coordination with GISCs, review and further develop the technical and operational specifications for the components and interfaces of WIS Centres and criteria for interoperability, certification and Quality Management of WIS Centres;
- (b) Review and develop the relevant aspects of the Manual on WIS (WMO-No 1060), the Guide to WIS (WMO No 1061) and associated informal guidance to better meet the needs of Members;
- (c) Review, further develop and oversee WIS monitoring activities, including those aspects of monitoring relating to the effectiveness of information exchange on behalf of the WWW and other Programmes, and take action to address issues that are identified by monitoring:
  - (i) Develop the technical specifications for DCPC and NC monitoring;
- (d) Review, develop and coordinate recommended practices and guidance on management of and access to operational information related to exchange of information through the WIS;
- (e) Contribute to the maintenance of WIS competencies related to NC and DCPC operations and associated training and learning guides;
- (f) Provide coordination and collaboration mechanisms for supporting the implementation and operation of WIS Centres, including:
  - (i) Coordination of the day to day operations of Regional Telecommunication Hubs and related World Weather Watch roles;
- (g) Advise the technical commissions and partner organizations on roles, responsibilities and implementation of NCs and DCPCs;
- (h) Assist WMO Members centres in implementing and maintaining compliant WIS interfaces and functions in NCs and DCPCs;
- (i) Identify implementation and operational issues requiring the urgent consideration of the OPAG on ISS;
- (j) Contribute to the maintenance of interoperability with GEOSS and SWIM to the benefit of Members.

### **Task Team on Global Information System Centres (TT-GISC)**

- (a) Review and further develop the technical and operational specifications for the components and interfaces of WIS Centres and criteria for interoperability, certification and Quality Management of WIS Centres:
  - (i) Coordinate the functions and interoperability of GISCs, including security, user management and metadata, collection and distribution catalogues to support GISC operations in backup mode and continue to develop the basic services of GISCs to take advantage of new information and communication technologies and practices;
- (b) Review and develop the relevant aspects of the Manual on WIS (WMO-No 1060), the Guide to WIS (WMO No 1061) and associated informal guidance to better meet the needs of Members;

- (c) Review, further develop and oversee WIS monitoring activities, including those aspects of monitoring relating to the effectiveness of information exchange on behalf of the WWW and other Programmes, and take action to address issues that are identified by monitoring:
  - (i) Develop the technical specifications for GISC monitoring;
- (d) Review, develop and coordinate recommended practices and guidance on management of and access to operational information related to exchange of information through the WIS;
- (e) Provide coordination and collaboration mechanisms for supporting the implementation and operation of WIS Centres;
- (f) Advise the technical commissions and partner organizations on roles, responsibilities and implementation of WIS Centres:
  - (i) Assist WMO Members' centres in implementing and maintaining compliant WIS interfaces and functions in NCs and DCPCs;
- (g) Identify implementation and operational issues requiring the urgent consideration of the OPAG on ISS;
- (h) Contribute to the maintenance of WIS competencies related to WIS operations and associated training and learning guides and facilitate training;
- (j) Contribute to the maintenance of interoperability with GEOSS to the benefit of Members.

#### **Expert Team on Centre Audit/Certification (ET-CAC)**

- (a) Operate the procedures for technical endorsement of WIS Centres and advise CBS on centres' level of technical compliance with standards and procedures:
  - (i) Validate and monitor the conformance of WIS Centres' interfaces to the agreed specifications and practices;
- (ii) Organize demonstrations of capabilities of candidate WIS centres as required, including onsite audits of GISCs;
- (b) Make recommendations to ICT-ISS regarding continuous improvement of the procedures for certification and periodic assessment of WIS centres
- (c) Advise ICT-ISS on systematic issues identified during certification and assessment activities.

#### **Inter-Programme Expert Team on Codes Maintenance (IPET-CM) (Was IPET-DRMM)**

Note: IPET-CM is expected to deliver its responsibilities through task teams that work by correspondence.

- (a) Review and maintain the Table Driven Code Forms by defining descriptors, common sequences, data templates and the regulations supporting these, including data representation of regional practices, so they meet the requirements of all Members, WMO Programmes and other concerned international organizations, such as ICAO;

- (b) Review and update guidance to Members and technical commissions on data representation, including national practices, and invite, coordinate and assist Members to validate modified or new data representations;
- (c) Review, develop and update the Manual on Codes (WMO-No 306) and associated reference and guidance material as required, and publish these in suitable electronic formats for human and automated use including codes.wmo.int;
- (d) Review and develop procedures and guidance to enable the interoperability of metadata and data between WMO standards and formats used within other communities, such as NetCDF, using the WMO Logical Data Model as a tool to achieve this;
- (e) Monitor conformance of data exchanged within the WIS and metadata records published to the WIS DAR catalogue with WMO data representation standards for utility and conformance with the guidance and WMO Core Metadata Profile, and develop action plans, including capacity-building, to address issues identified by monitoring;
- (f) Review and update the procedures used to maintain WMO data representations, taking into account opportunities presented by the WMO Logical Data Model;
- (g) Monitor progress towards and coordinate actions to implement migration to Table Driven Codes Forms;
- (h) Identify implementation issues requiring the urgent consideration of the OPAG on ISS;
- (i) Contribute to the maintenance of WIS competencies related to use of codes and associated training and learning guides and facilitate training.

**Inter-Programme Expert team on Data Representation Development (IPET-DRD)  
(Was IPET-MDRD)**

Note: IPET-CM is expected to deliver responsibilities through task teams that address specific issues.

- (a) Review and further develop the WMO Core Metadata Profile, WMO Logical Data Model and WMO standards for metadata and data exchange based on the ISO 19100 series of international standards (including XML) to meet the needs of Members, WIS, WMO Programmes and cooperating organizations such as ICAO;
- (b) Contribute to the review of and recommend updates to the Manual on Codes (WMO No. 306) and the Manual on the WMO Information System (WMO-No 1060) and associated reference and guidance material as required, publishing these in suitable electronic forms for human and automated use;
- (c) Review and update the procedures for maintaining and developing the WMO Core Metadata Profile, WMO Logical Data Model and WMO standards for metadata and data exchange based on the ISO 19100 series of international standards;
- (d) Propose to ISO and OGC changes to their respective standards that are required to meet the needs of WMO Members;
- (e) Advise Members, technical commissions and ICG-WIGOS on WMO Discovery Metadata, the WMO Logical Data Model and associated application schema and data interoperability issues;

- (f) Identify implementation issues requiring the urgent consideration of the OPAG on ISS;
- (g) Contribute to the maintenance of WIS competencies related to use of metadata and new model based data representation and associated training and learning guides and facilitate training.

**Expert Team on Communication Techniques and Systems (ET-CTS)**

Note: ET-CTS is expected to deliver its responsibilities through task teams that work by correspondence.

- (a) Maintain and develop recommended practices and technical guidance material for data communication techniques and procedures for use in the WIS, with a view to ensuring efficient and safe operations of information systems, and inform members of recent developments in standards bodies, in particular W3C, IETF, ITU and ISO;
- (b) Review and further develop the organization and design principles for the WIS data communication and access structure, and coordinate related pilot and implementation projects
- (c) Contribute to the development and maintenance of networks related WIS monitoring;
- (d) Review and amend as required the telecommunications components of the Manual on WIS (WMO-No 1060), the Manual on the GTS (WMO-No 386), their associated Guides and other guidance material;
- (e) Provide guidance on the technical, operational, administrative and contractual aspects of data communications services for WIS implementation at national, regional and global levels, including among others satellite telecommunications, managed data communications network services, cloud services and the Internet and co-ordinating cooperation with other organizations where appropriate to obtain operational benefits;
- (f) Review and further develop guidance and practices for planning, implementation and operation of data collection systems for observing systems for NMHSs, including interfaces with observation platforms, methods and data communications protocols;
- (g) Monitor the effectiveness of data exchange on the WIS in relation to the expected standards, and take follow-up action, including capacity-building activities, to address issues identified;
- (h) Facilitate the interaction between Members and International Organizations on telecommunications issues, including ensuring remote communities and areas with limited access to modern communication systems are properly catered for:
- (i) Identify implementation issues requiring the urgent consideration of the OPAG on ISS;
- (j) Contribute to the maintenance of interoperability with GEOSS and SWIM to the benefit of Members;
- (k) Contribute to the maintenance of WIS competencies related to network and cloud management and the associated training and learning guides and facilitate training.

**ICT-ISS Task Team on Information Management (TT-IM)**

- (a) Collaborate with technical commissions to review information management practices and develop and document appropriate standards and practices in information management;
- (b) Revise and generalise the "Guide on World Weather Watch Data Management (WMO No788)" to incorporate best practices for information management across all WMO programmes
- (c) Propose updates to incorporate standards and practices for information management under WIS Part C in the Manual on WIS (WMO No 1060) and Guide to the WIS (WMO No 1061).
- (d) Recommend updates to the WIS competencies related to information management and associated training and learning guides
- (e) Recommend procedures for the long term maintenance and development of standards and best practices related to information management.

**Ad hoc Inter-Commission Task Team on WIS (ITT-WIS)**

- (a) Recommend to ICT-ISS a process for making decisions impacting on the management of the capacity of WIS networks, including the process for agreeing that data may be designated as for global exchange (using the "GlobalExchange" keyword in the associated WIS Discovery Metadata record that controls routinely exchange between GISCs and contents of the WIS cache);
- (b) Recommend to ICT-ISS an escalation process for resolving issues that result from decisions made through the collaborative mechanisms established between the GISCs;
- (c) Propose to ICT-ISS a mechanism for gathering the expectations of Technical Commissions and Regional Associations for their requirements of what WIS would provide for them in the 2020s and beyond.
- (d) Inform ICT-ISS of the headline services that Technical Commissions and Regional Associations expected WIS to provide in the 2020s that could be used to guide the strategy for WIS before the detailed expectations had been gathered.

**OPAG DPFS**

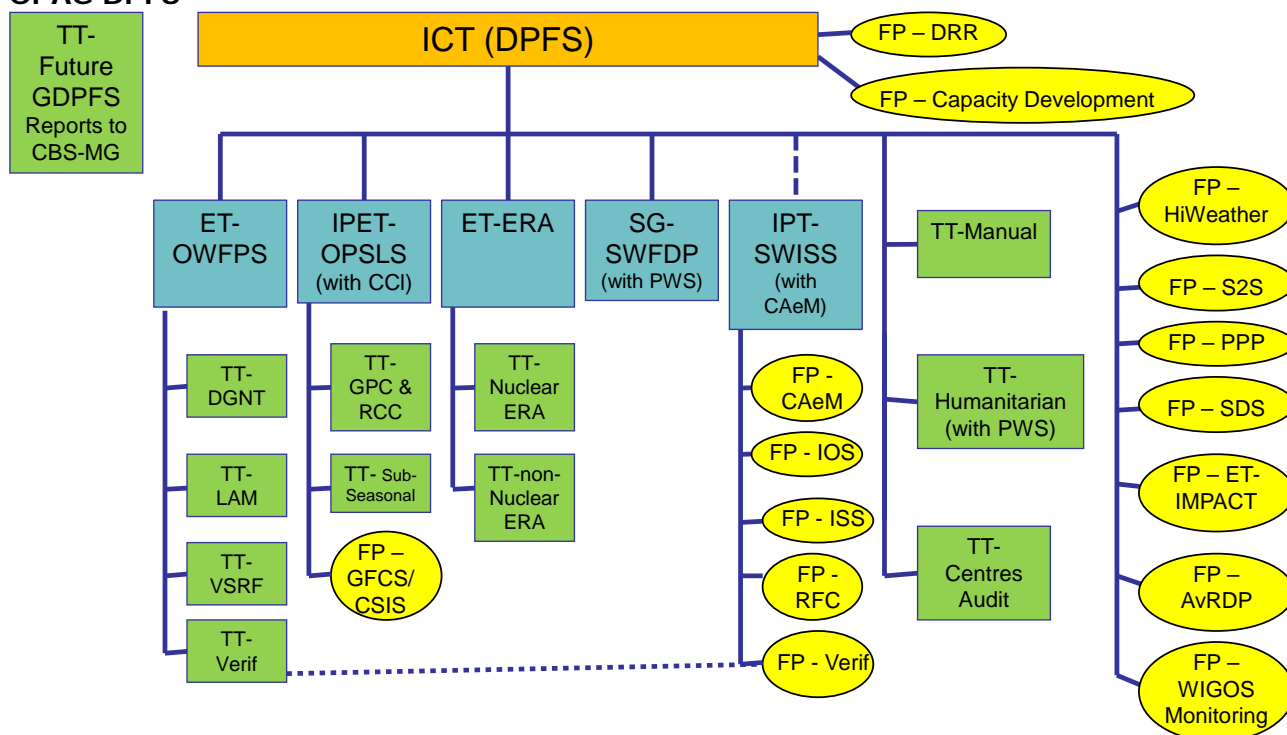

**(G)DPFS = (Global) Data Processing and Forecasting System**  
 OWFPS = Operational Weather Forecast Processes and Systems  
 OPSLS = Operational Prediction from Sub-Seasonal to Longer Timescales  
 ERA = Emergency Response Activities  
 SWFDP = Severe Weather Forecasting Development Project  
 SWISS = Space Weather Information Systems and Services  
 DRR = Disaster Risk Reduction  
 VSRF = Very Short Range Forecast (including Nowcasting)  
 DGNT = Development of Guidelines for Nowcasting Techniques

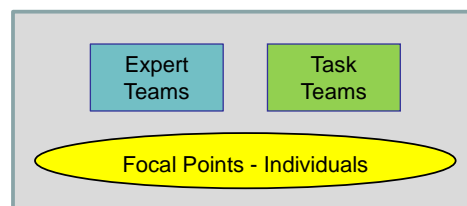

**Implementation Coordination Team on Data-Processing and Forecasting System (ICT-DPFS)**

- (a) Consider the requests and WMO priorities from Cg/EC;
- (b) Identify new emerging requirements (input required from RAs and other bodies);
- (c) Determine how GDPFS Centres can best contribute to fulfil emerging requirements;
- (d) Coordinate the implementation of decisions by CBS related to GDPFS and ERA;
- (e) Make recommendations to CBS concerning future work;
- (f) Review requirements and propose the establishment and activities of Task Teams, including Joint Task Teams;
- (g) Recommendations on technical regulations;
- (h) Recommendation on strategy for Future GDPFS.

**Expert Team on the Operational Weather Forecasting Process and Support (ET-OWFPS)**

- (a) Review the Manual on the GDPFS (WMO-No. 485) to ensure that procedures for forecasting systems and verification are adequate and meet CBS needs; propose updates as necessary;
- (b) Review GDPFS and Lead Centres' activities, support their developments and provide guidance as stated in the Manual;
- (c) Assess applications for GDPFS status against the designation criteria and make recommendations on designation to CBS;
- (d) Liaise with relevant WMO Programmes, Technical Commissions and international organizations as required to advise on requirements for practical implementations in operational systems;
- (e) Review new developments and advances in NWP and related systems, particularly with regard to severe and high impact weather forecasting;
- (f) Provide advice to NMHSs on NWP products, including EPS, for all forecast ranges, particularly with regard to severe and high impact weather forecasting;
- (g) Liaise with the PWS programme to promote and support the use and communication of NWP, especially probabilistic, information available from the GDPFS Centres; develop interpretation guidance to facilitate their use, and encourage feedback on usefulness and application;
- (h) Promote and support the education and training of forecasters on the use and interpretation of NWP products, including EPS, and their strengths and weaknesses;
- (i) Provide guidance on capacity building concerning the implementation of operational NWP systems, including verification systems, and/or the use of NWP products.

**Expert Team on Operational Predictions from Sub-Seasonal to Longer-Time Scales (ET-OPSLS)**

- (a) On the basis of requirements from Regional Climate Centres (RCCs), Regional Climate Outlook Forums (RCOFs) and NMHSs, and in the context of the Climate Services Information System (CSIS) of the Global Framework for Climate Services (GFCS), guide future development, outputs and coordination of components in the production of LRF. The components include Global Producing Centres (GPCs), Lead Centres for Long-range Forecast Multi-model Ensembles (LC-LRFMME), the Lead Centre for the Standardized Verification System for Long-range Forecasts (LC-SVSLRF) and other relevant bodies generating and providing LRF products;
- (b) In coordination with CCI, promote the use of GPC and LC forecast and verification products by RCCs, RCOFs and NMHSs, develop interpretation guidance to facilitate their use, and encourage feedback on usefulness and application;
- (c) Report on production, access, dissemination and exchange of LRF products and provide recommendations for future consideration and adoption by CAS, CCI, CBS, WCRP and other appropriate bodies;
- (d) In consultation with relevant experts in CAS and CCI and with the CBS Expert Team on Operational Weather Forecasting Process and Support (ET-OWFPS), review

developments in verification scores and practices with a view to updating the Standardized Verification System for Long-range Forecasts (SVSLRF);

- (e) Assess applications for GPC status against the designation criteria and make recommendations on designation to CBS;
- (f) Review the rules regarding user access to GPC and LC-LRFMME forecasts products;
- (g) Review the status of extended-range forecasting activities, and promote the availability and exchange of extended-range forecasts and verification products;
- (h) In close collaboration with WCRP, promote international cooperation and research on initialized predictions for timescales longer than seasonal and report on potential for operational predictions to CBS and CCI;
- (i) Review the Manual on the GDPFS (WMO-No. 485) and propose updates as necessary concerning extended and long-range forecasts.

The Expert Team shall comprise representatives from CBS and CCI to facilitate the necessary interactions and data flows between components of the CSIS. Team membership shall comprise representatives from GPCs and two CCI experts, one of which shall be the co-chair of CCI OPACE 3. In order to retain the existing focus on operational aspects, this team will report and propose amendments to the procedures and guidelines in the GDPFS to CBS through the ICT DPFS. Reporting to the CCI management group will be through the co-chair of OPACE-3.

#### **Expert Team on Emergency Response Activities (ET-ERA)**

- (a) Review the Manual on the GDPFS (WMO-No. 485) to ensure that procedures for ERA are adequate and meet CBS needs, and propose updates as necessary;
- (b) Promote and support the education and training of users on the use and interpretation of ERA products, and their strengths and weaknesses;
- (c) Identify the focal point of and liaise with relevant international organizations to advise on requirements for practical implementations in operational systems relevant to ERA;
- (d) Identify and promote technical resources which can assist NMHSs in developing their ERA capabilities for supporting national agencies in their preparedness, planning, response and recovering activities;
- (e) Review RSMC Environmental ERA's activities for various sources such as volcanic eruptions, dust storms, large fires, and nuclear and biological incidents, and provide guidance as stated in the Manual;
- (f) Test and improve the collective ability of all RSMCs, the IAEA, CTBTO, the RTH Offenbach and NMHSs in the environmental ERA to fulfil the operational requirements according to adopted standards and procedures stated in the Manual;
- (g) Explore the availability of atmospheric ash, dust, chemical, biological and radiological monitoring data and etc. for use in the RSMC operational environment.

### **CBS Task Team on the Provision of Operational Meteorological Assistance to Humanitarian Agencies (TT-HUM)**

The CBS Task Team on the Provision of Operational Meteorological Assistance to Humanitarian Agencies is established under the joint leadership/responsibility of the OPAGs on DPFS and PWS, and in liaison with other relevant Technical Commissions and Programmes. The CBS Task Team is chaired by the CBS Coordinator on DRR.

- (1) Based on the identified needs and requirements of humanitarian agencies, develop designation criteria and functions for existing GDPFS Centres that could specialize in the development and provision of operational meteorological products and services for mitigating the impacts of meteorological-related hazards;
- (2) Develop, in consultation with NMHSs, global and regional operational arrangements that would assist humanitarian agencies and disaster managers in mitigating disasters, taking into consideration the WMO Strategy for Service Delivery and the success of ERA, and provide assistance and support to strengthen NMHSs in this regard;
- (3) Assist Members, with or without NMHSs, in developing their capacity for supporting their government and humanitarian agencies in emergency preparedness efforts, including identifying the gaps in current capabilities and the opportunities to realize the benefits of addressing these gaps through close cooperation at regional and national levels.
- (3) Coordinate with relevant United Nations and international organizations on collecting and responding to their requirements;
- (4) Promote and support the education and training of users on the use, interpretation and delivery of meteorological products and services, and their strengths and limitations.

### **Steering Group on Severe Weather Forecasting Demonstration Project (SG-SWFDP)**

Members of the Steering Group on Severe Weather Forecasting Demonstration Project include: PWS focal point, representatives of Global and Regional projects.

- a) Giving guidance and monitoring the further development of existing and new regional projects;
- b) Managing the integration of new components in the SWFDP, including addressing synergies with other WMO Programmes;
- c) Developing recommendations to support the full and sustainable participation of NMHSs, including those from LDCs and SIDSs, in the SWFDP;
- d) Review and make recommendations on the scope of the cascading forecasting process.

### **DPFS Focal Points (FP-DPFS)**

- a) Provide support and guidance relevant to GDPFS to (a participating group);
- b) Coordinate with [ICT/ET] to meet the requirements from (a participating group).

**Task Team on Very Short Range Forecasts (TT-VSRF)**

- a) Develop document providing guidance on use and interpretation of VSRF products;
- b) Provide training module within SWFDP training workshop.

**Task Team on Standard Procedures for Verification (TT-SVP)**

- a) Carry out a study on interpolation methods for each surface parameter;
- b) Complete and review studies on verification of surface parameters;
- c) propose standard verification procedures for surface verification;

**Task Team on Limited Area Modelling (TT-LAM)**

- a) Development of the Guidance;
- b) Collect case studies of NMCs at various levels;
- c) Collect information on available LAM and Products from NWP centres.

**Task Team on the Development of Guidelines for Nowcasting Techniques (TT-DGNT)**

- a) Develop the Guidelines for nowcasting techniques. Areas of interest include:
  - Radar
  - Satellites
  - Lightning
  - NWP-based nowcasting systems (convective scale models)
  - Data assimilation of new observed data (e.g. dual-polarization Doppler Radar)
  - Nowcast ensemble systems
  - Lessons learned (do and don't)
  - Pro and con of operational nowcasting techniques
  - General approach to implementing nowcasting techniques
- b) In designing the guidelines, the team needs to consider that not all WMO Members Countries could implement a full fledged nowcasting system because of their limited resources. Therefore, the guidelines should consider nowcasting technique for those with limited resources.

**Task Team on Development of Audit Procedure for GDPFS Centres (TT-APGC)**

- a) Develop an efficient procedure for regular audit of GDPFS Centres;

- b) Review the reporting mechanism of the WMO Technical Progress Report on the Global Data-Processing and Forecasting System (GDPFS) and Numerical Weather Prediction (NWP) Research.

**Steering Group on Future GDPFS (SG-FDPFS)**

- a) Develop the Vision for the future GDPFS, including requirements and objectives, scope, and its anticipated benefits;
- b) Develop strategies to support the Vision (including governance, management, roles and responsibilities, deliverables and milestones, monitoring and review, risk assessment, and resources);
- c) Develop implementation plan in alignment with the strategies;
- d) Promote and monitor the implementation of the Vision;
- e) Coordinate with relevant WMO Programmes and Technical Commissions in accordance with the above terms.

**IPT-SWISS (see [Annex 6](#))**

The draft terms of reference for IPT-SWISS are in [Annex 6](#).

**OPAG PWSD**

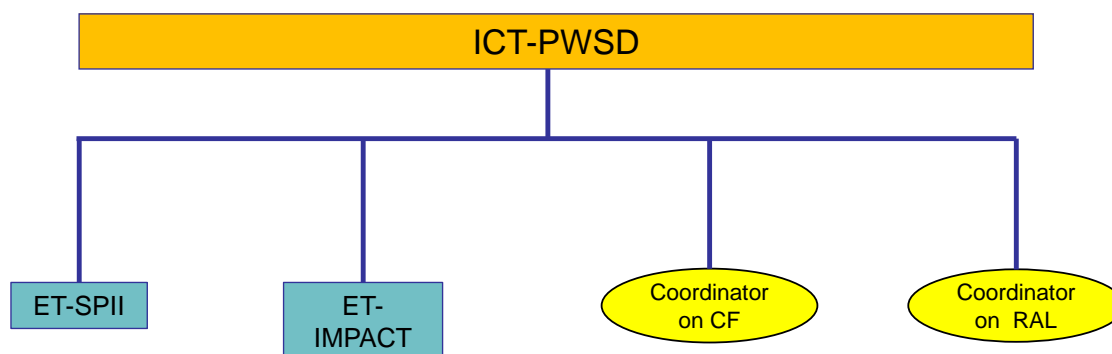

**PWSD = Public Weather Service Delivery**

SPII = Service Provision Innovation and Implementation  
 IMPACT= Impact-based Forecast and Risk-based Warning  
 RAL = Regional Association Liaison  
 CF = Competency Framework

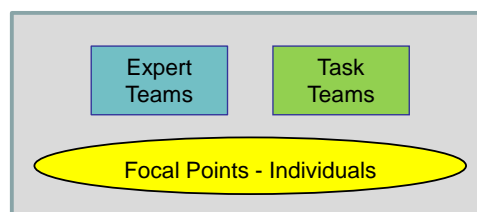

**Implementation-Coordination team on Public Weather Service Delivery (ICT-PWSD)**

- (a) Coordinate the implementation of the decisions of Congress, the Executive Council and the Commission for Basic Systems (CBS) with respect to Public Weather Services;
- (b) Consult and collaborate to ensure coordination of the work of the Open Programme Area Group (OPAG) on PWSD with that of other CBS OPAGs, technical commissions (TCs), EC Working Groups, regional associations (RAs) and WMO Programmes and initiatives;
- (c) Support a strengthening of partnerships between National Meteorological and Hydrological Services (NMHSs), other agencies, and user sectors (e.g., media, health, emergency management) in areas relevant to PWSD;
- (d) Through the constituent teams of the OPAG, promote the implementation of the WMO Strategy for Service Delivery in the context of Public Weather Services, and making full use of emerging technologies;
- (e) Keep under review the work of the PWSD Expert Teams and co-ordinate and guide their work programmes;
- (f) Continue to encourage and provide guidance to Members to assert the authority of NMHSs as the sole providers of official high-impact weather warnings;

- (g) Facilitate the development of guidance and training material to underpin and support those elements of the WMO competency framework relevant to PWS-related activities;
- (h) Support and promote excellence in communication as a key enabler of quality service delivery;
- (i) Collaborate with development partners and other WMO entities to assist NMHSs in the identification and assessment of societal, economic and environmental benefits of hydro-meteorological services; and
- (j) Continue to promote the awareness and use of guidance documents developed through the work of the OPAG, in collaboration with Regional Associations, and by other means;
- (k) Guide the work of the OPAG to assist Members in developing their capacity to deliver improved services through the use of the best science and emerging technologies.

#### **Expert Team on Service Provision Innovation and Improvement (ET-SPII)**

- (a) Monitor, evaluate and advise on challenges and opportunities for Public Weather Service Delivery presented by developing science and technology;
- (b) Address the user requirements identified by ET/ IMPACT for data provision, management and visualisation, through collaboration with DPFS and other partners as necessary;
- (c) Take responsibility for, and review PWS guidance on, scientific and technical aspects of Service Delivery improvement, including nowcasting, uncertainty, CAP and mobile/web services;
- (d) Identify experts to advice on technical aspects of Service Delivery improvement as required;
- (e) Provide oversight, quality assurance and coordination of the continuing development of WWIS/SWIC.

#### **Expert Team on Impact-Based Forecasting and Risk-Based Warning (ET-IMPACT)**

- (a) Building on the WMO Guidelines on Multi-hazard Impact-Based Forecast and Warning Services (WMO No. 1150), develop an implementation strategy which describes next actionable steps and evolution;
- (b) Develop and maintain an expert resource to facilitate activities and projects in the area of Impact-Based Forecasting, including representatives from the social sciences;
- (c) Create a network of champions, ambassadors, and change agents within NMHSs, their partners, and users to support and promote Impact-Based Forecasting.
- (d) Actively promote Impact-Based Forecasting by sharing best practices through symposiums, journal papers and communication outlets;
- (e) Provide NMHSs with guidance on how to standardize Impact-Based Forecasting messaging protocols and formats (e.g. colour-coding, language, icons etc.);

- (f) Working with Technical Commissions, Regional Associations, and ET/SPII within the OPAG/PWSD, establish user requirements for service improvements through science and technological innovation;
- (g) Evolve current methodologies for verification and evaluation to incorporate a focus on Socio-Economic Benefits.

**Coordinator on the Competency Framework (C-CF)**

- (a) Facilitate the development of guidance and training material to underpin and support those elements of the WMO competency framework relevant to activities related to PWS.

**PWSD Coordinator on Regional Association Liaison (R-RAL)**

- (a) Consult and collaborate to ensure coordination of the work of the Open Programme Area Group (OPAG) on PWSD with Regional Associations (RAs) and their subsidiary bodies.

## **ANNEX 6: DRAFT TERMS OF REFERENCE OF IPT-SWISS**

### **Scope**

The responsibility of the Inter-Programme Team on Space Weather Information, Systems and Services (IPT-SWISS) is to coordinate space weather activities within the WMO Programmes, to maintain linkage with the constituent bodies and their relevant subsidiary groups, to maintain linkage with partner organizations, and to provide guidance to WMO Members. IPT-SWISS is established under Commission for Basic Systems (CBS) and the Commission for Aeronautical Meteorology (CAeM) who will provide joint oversight in consultation with each other via their presidents.

### **Main tasks**

- (a) Integration of Space Weather observations, through review of space- and surface-based observation requirements, harmonization of space-based sensor specifications, monitoring plans for Space Weather observations;
- (b) Standardization and enhancement of Space Weather data exchange and delivery through the WMO Information System (WIS);
- (c) Coordinating the development of SPW best practices for end-products and services, including e.g. quality assurance guidelines and emergency warning procedures, in collaboration with aviation and other major application sectors;
- (d) Encouraging the dialogue between the research and operational space weather communities;
- (e) Organization of capacity building, training and outreach activities towards WMO Members and space weather potential users;
- (f) Provision of guidance to WMO Members and programmes on space weather matters, and conduct appropriate actions as requested by CBS and CAeM.

### **Composition**

IPT-SWISS will be composed of members nominated by the relevant technical commissions, points of contacts nominated by the regional associations and associate members including representatives of ISES and other partners or major user applications.

IPT-SWISS members shall cover the various fields of expertise necessary to address space weather matters within WMO and will contribute to the relevant expert teams or other groups of WMO technical commissions including: Commission for Basic Systems (CBS)<sup>1</sup>; Commission for Aeronautical Meteorology (CAeM)<sup>2</sup>; Commission for Instruments and Methods of Observation (CI MO); Commission for Atmospheric Sciences (CAS).

IPT-SWISS will form ad hoc teams as appropriate focusing on topics requiring a particular field of expertise, for a particular time frame.

---

<sup>1</sup> Such as the Inter-Programme Expert Teams on Observing System Design and Evolution (IPET-OSDE), on WIGOS Framework Implementation (IPET-WIFI), on Data Representation Maintenance Monitoring (IPET-DRMM), on Metadata and Data Representation Development (IPET-MDRD), or the Steering group on Radio-Frequency Coordination (SG-RFC).

<sup>2</sup> Such as the Expert Team on Aviation, Science and Climate (ET-ASC), on Information & Services for Aviation (ET-ISA), on Education, Training and Competencies (ET-ETC).

**ANNEX 7: DRAFT RESOLUTION 6.1.X/1 (EC-68)**

**FOUR-YEAR PLAN FOR WMO COORDINATION OF SPACE WEATHER RELATED ACTIVITIES**

THE EXECUTIVE COUNCIL

**Recalling** Resolution 38 (Cg-17) on WMO Coordination of Space Weather Activities,

**Noting:**

- (1) The impact of Space Weather on observation and telecommunication infrastructures, aviation and maritime safety, energy distribution networks, and satellite-based navigation services, among other areas,
- (2) The need for a coordinated effort by Members to address the observing and service requirements to protect against the hazards of space weather as stated by the Sixteenth WMO Congress,
- (3) The potential for synergy between the delivery of space weather services and of meteorological services,

**Having regard** to the need to support the joint work of WMO and the International Civil Aviation Organization towards operational space weather services for international air navigation by 2018,

**Having considered** the Four-year Plan for WMO Coordination of Space Weather Related Activities, given in Annex to this Resolution,

**Acknowledging** that this plan aims at the integration of WMO space weather related activities into existing WMO programmes and activities, including the integration of space weather observations into the WMO Integrated Global Observing System,

**Noting** that the working mechanisms and responsibilities to implement this plan have been coordinated between the Presidents of the Commission for Aeronautical Meteorology and of the Commission for Basic Systems, with a view to efficiently provide joint oversight by CAeM and CBS,

**Noting further** that the terms and definitions related to space weather have been reviewed in consultation with the space weather science community,

**Approves** the Four-year Plan for WMO Coordination of Space Weather Related Activities,

**Requests:**

- (1) Members to support the implementation of the planned activities with participation of experts, in-kind contributions and contributions to the Space Weather Trust Fund,
- (2) The Secretary-General to take appropriate actions to support these activities in partnership with relevant organizations such as the International Space Environment Service, as well as national and international agencies,
- (5) The Secretary-General to submit to the Eighteenth World Meteorological Congress a report on the achieved results and a proposal for future actions in this domain.

-----

Annex: 1 *[Comment: the revised draft four-year plan will be provided in the Annex]*

## ANNEX 8: SPACE WEATHER TERMINOLOGY

	English	French
1	<p><b>Climate of space, space climate</b> The statistical properties and long-term variations of the physical and phenomenological state of the space environment.</p>	<p><b>climat de l'espace</b> Propriétés statistiques et variations à long terme de l'état physique et phénoménologique de l'environnement spatial.</p>
2	<p><b>Climatology of space, space climatology</b> The study of the statistical properties of the physical and phenomenological state of the space environment, its long-term variations and their impacts on the Earth environment.</p>	<p><b>climatologie de l'espace</b> Étude des propriétés statistiques de l'état physique et phénoménologique de l'environnement spatial, de ses variations à long-terme et de leur impact sur l'environnement terrestre.</p>
3	<p><b>geospace</b> The region of space near the Earth, including the upper atmosphere and the area of influence of the Earth's magnetic field</p> <p><i>Note: Not to be confused with "geospatial" matters which relate to the use of satellite techniques in Geographic Information Systems (GIS)</i></p>	<p><b>géoespace</b> Région de l'espace proche de la Terre, comprenant la haute atmosphère et la zone d'influence du champ magnétique terrestre.</p> <p><i>Note : Ne pas confondre avec l'adjectif « géospatial », qui concerne l'application des techniques satellitaires dans les systèmes d'information géographique (SIG).</i></p>
4	<p><b>meteorology of space</b> (See: "space weather", which is the usual expression in English)</p> <p><i>Note: "meteorology of space" should not be confused with "space meteorology", which is the study of atmospheric properties through the use of satellites.</i></p>	<p><b>météorologie de l'espace</b> (Voir ci-dessous)</p> <p><i>Note : Ne pas confondre la « météorologie de l'espace » avec la « météorologie spatiale », qui concerne l'utilisation des satellites pour étudier les propriétés de l'atmosphère.</i></p>
5	<p><b>space weather</b> 1. [Space environment] The physical and phenomenological state of the natural space environment, including the Sun and the interplanetary and planetary environments.</p>	<p><b>météorologie de l'espace</b> 1. [Environnement spatial] L'état physique et phénoménologique de l'environnement spatial naturel, comprenant le soleil et les environnements interplanétaire et planétaires.</p>

6	<p><b>space weather</b> 2. <i>[Meteorology of space]</i> The discipline which aims at observing, understanding and predicting the state of the Sun, of the interplanetary and planetary environments, their disturbances, and the potential impacts of these disturbances on biological and technological systems.</p>	<p><b>météorologie de l'espace</b> 2. <i>[Discipline]</i> La discipline qui vise à observer, comprendre, et prévoir l'état du soleil, des environnements interplanétaire et planétaires, leurs perturbations, et l'impact potentiel de ces perturbations sur les systèmes biologiques et technologiques.</p>
7	<p><b>space weather related,</b> Related to the state of the natural space environment, <b>space weather bulletin,</b> bulletin describing observed or predicted space weather conditions, <b>space weather alert</b> alert related to a space weather event</p>	<p><b>spatiométéorologique,</b> Relatif à la météorologie de l'espace, <b>bulletin spatiométéorologique,</b> bulletin décrivant les conditions observées ou prévues de la météorologie de l'espace, <b>alerte spatiométéorologique</b> alerte relative à un évènement de météorologie de l'espace.</p>

	Russian	Spanish
1	<b>климат космоса, космический климат</b> Статистические свойства и долгосрочные изменения физического и феноменологического состояния космической среды.	<b>clima del espacio</b> Propiedades estadísticas y variaciones a largo plazo del estado físico y fenomenológico del entorno espacial.
2	<b>климатология космоса, космическая климатология</b> Изучение статистических свойств физического и феноменологического состояния космической среды, ее долгосрочных изменений и их воздействий на окружающую среду Земли.	<b>climatología del espacio</b> Estudio de las propiedades estadísticas del estado físico y fenomenológico del entorno espacial, de sus variaciones a largo plazo y de su impacto sobre el entorno terrestre.
3	<b>геокосмос</b> Околоземное космическое пространство, включающее верхнюю атмосферу и область воздействия магнитного поля Земли. <i>Примечание: не следует путать с «геопространственными» вопросами, которые относятся к использованию спутниковых методов в географических информационных системах (ГИС).</i>	<b>geoespacio</b> Región del espacio cerca de la Tierra que incluye la alta atmósfera y la zona de influencia del campo magnético de la Tierra. <i>Nota: No debe confundirse con el adjetivo "geoespacial" que se refiere a la aplicación de las técnicas satelitales en los Sistemas de información geográfica (SIG).</i>
4	<b>метеорология космоса (см. космическая погода)</b> <i>Примечание: «метеорологию космоса» не следует путать с «космической метеорологией», которая занимается исследованием свойств атмосферы с использованием спутников.</i>	<b>meteorología del espacio</b> (Véase a continuación) <i>Nota: La "meteorología del espacio" no debería confundirse con la "meteorología espacial", que se ocupa del uso de satélites para estudiar las propiedades de la atmósfera.</i>
5	<b>космическая погода</b> 1. [Космическая среда] Физическое и феноменологическое состояние естественной космической среды, включая Солнце, межпланетную и планетарные среды.	<b>tiempo espacial</b> 1. [Entorno espacial] Estado físico y fenomenológico del entorno espacial natural, incluido el Sol, y los entornos interplanetarios y planetarios.
6	<b>Космическая погода</b> 2. [Метеорология космоса] Дисциплина, направленная на осуществление наблюдений за Солнцем, межпланетной и планетарными средами, изучение и предсказание их состояния, а также возмущений и потенциальных влияний этих возмущений на биологические и технологические системы.	<b>meteorología del espacio</b> 2. [Disciplina] Disciplina que pretende observar, entender, predecir el estado del Sol, de los entornos interplanetario y planetarios, sus perturbaciones, y los posibles efectos de estas perturbaciones en los sistemas biológicos y tecnológicos.
7	<b>связанный с космической погодой</b> Связанный с состоянием естественной космической среды.	<b>espaciometeorológico,</b> Relativo a la meteorología del espacio,

	<p><b>бюллетень космической погоды</b> Бюллетень, описывающий наблюдаемые или прогнозируемые условия космической погоды. <b>оповещение о неблагоприятном состоянии космической погоды</b> Оповещение, связанное с каким-либо явлением космической погоды.</p>	<p><b>boletín espaciometeorológico,</b> boletín que describe las condiciones observadas o previstas de la meteorología del espacio, <b>alerta espaciometeorológica</b> alerta relativa a un evento de meteorología del espacio.</p>
	<b>Arabic</b>	<b>Chinese</b>
1	<p><b>مناخ الفضاء</b> الخصائص الإحصائية للحالتين المادية والفيولوجية للبيئة الفضائية وتبايناتها على المدى الطويل.</p>	<p><b>空间气候</b> 空间环境的物理和现象学状态的统计特征和长期变量。</p>
2	<p><b>علم مناخ الفضاء</b> دراسة الخصائص الإحصائية للحالتين المادية والفيولوجية للبيئة الفضائية وتبايناتها على المدى الطويل، وآثارها على البيئة الأرضية.</p>	<p><b>空间气候学</b> 关于空间环境的物理和现象学状态的统计特征、其长期变量及其对地球的影响的研究。</p>
3	<p><b>الفضاء الأرضي</b> المنطقة من الفضاء القريبة من الأرض، والتي تشمل الغلاف الجوي العلوي وحيز التأثير للمجال المغنطيسي الأرضي. ملاحظة: يجب عدم الخلط بين هذا المصطلح ومفردة "الجيوفضائية" التي تتعلق باستخدام التقنيات الساتلية في نظم المعلومات الجغرافية (GIS).</p>	<p><b>地球空间</b> 接近地球的空间区域，包括高层大气和影响地球磁场的区域 注：不应与“地理空间”问题混淆，后者涉及“地理信息系统”（GIS）中卫星技术的应用</p>
4	<p><b>- أرصاد الفضاء</b> ملاحظة: ينبغي عدم الخلط بين " أرصاد الفضاء " و"الأرصاد الفضائية" والتي تعنى استخدام السواتل لدراسة الغلاف الجوي</p>	<p><b>空间气象 (见空间天气)</b> 注：“空间气象”不应与“空间气象学”混淆，后者是利用卫星开展的大气特性研究。</p>
5	<p><b>- طقس الفضاء</b> 1- [البيئة الفضائية] الحالة المادية والفيولوجية للبيئة الفضائية الطبيعية، بما في ذلك الشمس والبيئات فيما بين الكواكب والبيئات الكوكبية.</p>	<p><b>空间天气</b> 1、[空间环境]太阳、行星际和行星环境等自然空间环境的物理状态和现象。</p>
6	<p><b>- رصد طقس الفضاء</b> [مجال تخصص] مجال تخصص الغرض منه رصد حالة الشمس والبيئات فيما بين الكواكب وكذا البيئات الكوكبية، والاضطرابات التي تلحق بها و التأثير المحتمل لهذه الاضطرابات علي النظم الحيوية والتكنولوجية، وكذا فهم هذا الظواهر والتنبؤ بها.</p>	<p><b>空间天气</b> 2、[空间气象]旨在观测、探索和预测太阳、行星际和行星环境等自然空间环境的状态、（空间环境）扰动、以及这些扰动对生物系统和技术系统的潜在影响的学科。</p>
7	<p><b>المتصل برصد طقس الفضاء</b> <b>المرتبط برصد طقس الفضاء</b> <b>بيان رصد طقس الفضاء</b> بيان يصف حالات الطقس التي تم رصدها أو التنبؤ بها الخاصة بالفضاء. <b>إنذار مرتبط بطقس الفضاء</b> إنذار بشأن ظاهرة من ظواهر طقس الفضاء</p>	<p><b>空间天气相关：</b> 和自然空间环境状态相关的； <b>空间天气公告：</b> 描述监测或预测的空间天气状态； <b>空间天气警报：</b> 预警某一空间天气事件的相关信息</p>

## **ANNEX 9: PROPOSED TERMS OF REFERENCE FOR WMO COORDINATION GROUP ON OPERATIONAL WEATHER RADARS**

- 1) Under the governance of CIMO and the joint management of CIMO and CBS, act as the WMO primary coordination group and focal point for all operational meteorological radar (S, C and X band) matters and related WMO activities, including:
  - a. WIGOS framework and operational development and implementation;
  - b. Standardization of, and regulations and guidance on, systems requirements and specifications, quality control, maintenance and operation, data processing algorithms, data products and data quality monitoring;
  - c. Radio-frequency allocation and protection;
  - d. Methods, models and formats for the international exchange of meteorological radar data and metadata;
  - e. Response to requirements of data users; and
  - f. Training and capacity development.
- 2) Maintain an active watch and report on potential operational developing and emerging meteorological radar research and technologies;
- 3) Liaise and coordinate activities, as appropriate and as directed, with other international and regional organizations on relevant matters, particularly including international standards organizations and research bodies and associations.
- 4) Liaise with and respond to the various requests of WMO bodies and Technical Commissions and their associated work teams and groups on mutual and relevant matters of responsibility.
- 5) Develop and document strategies and plans for the activities of the CG-OWR under the direction of and subject to the approval of the management board.
- 6) Report on issues, activities and progress to the governing Technical Commissions through the CIMO OPAG on Remote-Sensing Technologies, and the CBS OPAG on Integrated Observing Systems.

### **Membership**

Recommended that the initial membership of CG-OWR should:

- include experts on meteorological radars in CIMO/ET-ORST and CBS/ET-SBO and TT-WRDE;
- have geographical representation across WMO regions; and
- include representation of the countries and regional organizations with large and advanced radar networks.
- As soon as possible, membership should include representation from:

- CHy
- CCL
- CAeM
- CAS

### **Possible Priority Tasks and Work Plan Activities**

- a) CIMO RQQI activity.
- b) CBS weather radar data exchange activity;
- c) Assistance and advice on WMO coordination with ISO on radar matters;
- d) Development of integrated rainfall products;
- e) In consultation with relevant WMO Members and WMO Education and Training Branch, development of training curriculum and associated materials in support of WMO international training courses and workshops on operational meteorological radar systems;
- f) Attend and publish technical reports on relevant aspects of key international meteorological radar conferences, particularly including AMS Radar Conference and ERAD (2 members to attend);
- g) Coordination of/assistance with international training courses, e.g. TSMS and KMA;
- h) Development of functional requirements and specifications of Regional WIGOS Centers on Meteorological Radar Operation and Maintenance;
- i) Organisation of WMO international conferences on meteorological radar systems (e.g. every 2-4 years) in collaboration with AMS and/or ERAD;
- j) Development of an operational plan for CG-OWR.

**ANNEX 10: MANAGING MANUALS AND GUIDES THAT ARE RELEVANT TO CBS**

Manual	Name	Section	Team	Technical Specification
<b>OPAG IOS</b>				
WMO No. 1160	Manual on the WMO Integrated Global Observing System	All	IPET-WIFI	
WMO No. ??	Guide to the WMO Integrated Global Observing System	All	IPET-WIFI	
		Introduction, Part I (General), Appendix	ICT-IOS	
		Part II (Requirements)	IPET-OSDE	
		Part III (Surface-based)	ET-SBO	
		Part III, 2.3.3, 2.12.10, 3.3.9, 3.3.10	ICT-IOS, in consultation with JCOMM	
		Part III, 2.5, 2.12.6, 2.12.7	ET-ABO	
		Part III, 2.9, 2.10	ICT-IOS, in consultation with GCOS	
		Part III, 2.11	ICT-IOS, in consultation with CAgM	
		Part III, 2.12.18	ICT-IOS, in consultation with CAS	
		Part IV (Space-based), sections 1, and 2.1 to 2.6	ET-SAT	
		Part IV (Space-based), sections 2.7, 2.8, and 3	IPET-SUP	
		Part V (QC)	ET-SBO	
WMO No. 488	Guide to the Global Observing System	Introduction, Part I (Purpose, ...), Annex	ICT-IOS	
		Part II (Requirements)	IPET-OSDE	
		Part III (Surface-based), Part V (Reduction of level data), Part VI (QC), Part VII (Monitoring), Part VIII (QM)	ET-SBO	
		Appendices III.1, III.2, III.3	ET-SBO	
		3.2.1.3, 3.2.2.3, 3.3.2.7 (ASAP part), 3.6, 3.9.2.8	JCOMM	

Manual	Name	Section	Team	Technical Specification
		3.4, 3.9.2.4, 3.9.2.5	ET-ABO	
		3.5	CAeM	
		3.7	CCI	
		3.8	CAGM	
		3.9.2.6	CAS	
		Part IV (Space-based)	IPET-SUP	
<b>OPAG ISS</b>				
WMO No. 1060	Manual on the WMO Information System	Requirements on centres (Parts I-IV)	ET-WISC	Appendix A,
		WIS Discovery Metadata (Part V)	IPET-MDRD	Appendix C Part 2 section 3 (Data Dictionary)
WMO No. 1061	Guide to the WMO Information System	Requirements on centres (Parts I-IV)	ET-WISC	
		WIS Discovery Metadata (Part V)	IPET-MDRD	Part V metadata guidance
		Training and Learning Guide	ICT-ISS	Annex D
WMO No. 386	Manual on the Global Telecommunications System,	Attachment II-5	IPET-DRMM	Attachment II-5
		WWW monitoring	ICT-ISS	
		Remainder	ET-CTS	Attachments I-1 and I-2
WMO No. 1115	Guide to Information Technology Security		ET-CTS	Whole document
WMO No. 1116	Guide to Virtual Private Networks (VPN) via the Internet between GTS centres		ET-CTS	Whole document
WMO No. 306	Manual on Codes	Vol I.1	IPET-DRMM	FM 15, FM 16, FM 51, FM 53, FM 54, table 4678
		Vol I.2	IPET-DRMM	All code tables
		Vol. I.3	IPET-MDRD	All code tables
WMO No. 788	Guide on World Weather Watch Data Management		ICT-ISS	
<b>OPAG DPFS</b>				
WMO No 485	Manual on the Global Data-processing and Forecasting System		ICT-DPFS	

<b>Manual</b>	<b>Name</b>	<b>Section</b>	<b>Team</b>	<b>Technical Specification</b>
WMO No. 305	Guide on the Global Data-processing System		ICT-DPFS	
WMO No. 636	Guide on the Automation of Data-processing Centres		ICT-DPFS	
<b>OPAG PWS</b>				
WMO No. 834	Guide to Public Weather Services Practices		ICT-PWS	

**ANNEX 11: ACTIONS PROPOSED TO PTC-2016 FOR A ROADMAP TO ENHANCED WMO TECHNICAL REGULATIONS FRAMEWORK BY CG-18 (2019):**

1. All TCs to plan at the earliest opportunity the update of relevant TR Volume sections, Manuals and Guides, e.g., at their management bodies meetings
2. Designate responsible person(s) for each publication and notify Secretariat.
3. Promote the use of the WMO-No.1127 through a presentation at each TC session
4. Adopt performance-based approach with focus on functional and performance requirements (e.g., in defining regional centres).
5. Conduct another training session (or 1-day training prior to each TC session).
6. Develop the missing chapters of the Vol 1 according to new outline (*CBS-MG note: see [document 29-A](#)*)
7. Conduct a survey with WMO Members on the quality and usefulness of the existing technical regulation material (including, "missing Manuals and Guides").
8. Decide on the right placeholder for detailed technical specification, their update and approval process (e.g., WMO-No. 306).
9. Decide on approval process for Guides.
10. Consider a content management system CMS system for all WMO TRs.
11. Streamline the monitoring of compliance (with RAs).
12. Develop and make available to Members "Compliance Check Lists" and other self-assessment tools
13. Pilot project on "Member's Compliance Audit" (e.g., one big and one small State).

## **ANNEX 12: YEAR OF POLAR PREDICTION (YOPP) ELEMENTS FOR CONSIDERATION BY CBS-16**

Below are a few elements coming from the YOPP summit that require a specific involvement from global centers and that could be considered by CBS-16.

### **User-relevant aspects and verification**

Several forecast and verification end-users and priority sectors were identified by participants, and the complexity of user needs was recognized. Participants agreed that user- engagement and associated social science studies are necessary to serve the YOPP objectives. User-tailored products and services should be developed, hosted and evaluated within multi- disciplinary testbeds (e.g., the NOAA/NWS Arctic Test Bed, Alaska).

### **Observations**

A coordinating role of PPP and YOPP was stressed during the discussions. It was agreed that this is the way to make the bottom-up approach to observational campaigns, often focused on process studies, fit best the goals of YOPP. Namely, there was agreement on the following items:

- A structured list of observations should be introduced into the Implementation Plan of YOPP dividing all possible/planned observations into categories like: i) observations going to GTS; ii) GTS-like observations; iii) process studies, etc. The aim of that is to provide a clearer view on the observational component of YOPP to a broad range of users, modelers, etc.
- Good coordination with the Satellite community is needed.
- Planning of the IOPs should primarily consider the demands and drawbacks of the current data assimilation systems, especially the coupled ones.

### **Modelling, data assimilation, linkages and prediction**

Participants recognized that, both in the YOPP Implementation Plan and during the YOPP Summit, the design of coupled high-resolution prediction systems has garnered limited attention. A central question is whether one can expect to have at least one operational *coupled* system ready by the YOPP, covering a pan-Arctic domain and issuing forecasts at timescales of more than a few hours/days (with spatial resolution of ~10 km or finer). Such a system is currently the missing piece to bridge operational forecasting and seasonal climate forecasting.

Advancing data assimilation systems should be a key activity within YOPP. A key prerequisite for making progress will be knowing the error structure of models used for producing reanalyses, reconstructions, or initializations of predictions. Furthermore, it was strongly recommended that YOPP continues to rely on the activities of the World Weather Research Programme (WWRP) Data Assimilation and Observing Systems (DAOS) and data denial experiments in order to determine the value added from particular observations collected during the YOPP.

### **YOPP data legacy**

There was agreement among the Summit participants that the lessons learned during the last IPY should feed into the development of the YOPP data legacy. It was recommended, therefore, to develop a YOPP data portal that exploits the expertise gained with the Global Cryosphere Watch (GCW) portal. This includes the use of consistent meta data and pointers to other online locations, where data can be retrieved. A small number of data centres that are willing to archive YOPP data (and support the process) and able to provide digital object identifiers (DOIs), such as PANGAEA, should be identified. Data sets must be open access and,

where observations could facilitate real- time operational use, submission of data through the GTS/WIS should be mandatory. Special attention should be given to WMO standard including BUFR formats. Finally, all data sets should be published in data journals such as Earth System Science Data (ESSD), and it was argued that the YOPP data legacy could be improved by having a YOPP special issue in ESSD.

## **Appendix of Annex 12**

### ***The main YOPP scheduled periods***

The main YOPP period is scheduled from mid-2017 to mid-2019. Given the relatively high costs of taking observations in polar regions, it is necessary to agree on at least two intensive observing periods (IOPs), both for the Arctic and Antarctica.

- For the Southern Hemisphere, the importance of accurate predictions during austral summer for key stakeholders such as the logistics community and the tourism industry together with enhanced research capacity during the summer season makes the period December 2018 to February 2019 a good starting point for further discussions.

For the Arctic the situation is different. It was decided to have two IOPs in the Arctic, with one covering a full open-water season and one focusing on wintertime.

- The first IOP covers early summer to late autumn. There is clearly a need to start the IOP in early summer to ensure that sub-seasonal and seasonal predictions of summer time conditions, when most of economic activities take place, are well initialized. To improve summer predictions on shorter time scales (hours to days), on the other hand, it will be important to enhance observational capacity from June to September. It was strongly argued for extending the first IOP to late autumn, since it is in late autumn that atmosphere- sea ice-ocean interactions are most vigorous with implications for sub-seasonal and seasonal predictions, both in the Arctic and lower-latitudes, and to capture the full open- water season for operational forecasting needs.

- The second IOP is shorter, covering the boreal winter (January to March). This IOP is intended to address topics such as polar lows, snow prediction and initialization of seasonal and longer-term predictions.

