

Determination of Corrections for Measuring Amount of Rainfall Using the Standard Rain Gauge

by

Ferdinand Y. Barcenas, Weather Specialist II
Philippine Atmospheric Geophysical and Astronomical Services Administration (PAGASA)
Science Garden Complex, Diliman, Q. C.
Philippines 1101
Tel. & Fax.: (632) 9292121
E-mail: fybarce8@yahoo.com

Abstract

The standard rain gauge is being used in the Philippines for quite a long time than any other type of rain gauge, or before the advent of the popular tipping bucket rain gauge. It is used until now and is being reproduced locally to sustain the needs of our national meteorological agency, which are supplied at our manned weather stations. It is actually a 20 centimeters or the 8 inches rain gauge with a measuring tube inside to magnify ten times the actual depth or amount of rainfall for ease of reading.

This rain gauge is being measured by means of measuring stick graduated such that the magnification is reduced back to its actual or original amount of rainfall. Dipping the measuring stick in the measuring tube provides an error due to the volume of the measuring stick depending on the height of rainfall being measured and also of the dimensions of the measuring stick, tube and the catch of the collecting funnel. This error has a significant indication considering a long time period of observations and especially during rainy season. This has to be shown that it can be corrected or formulated. The error due to this measurement process has to be considered for it is more quantifiable than wetting losses and evaporations in a standard rain gauge. Comparatively, the tipping bucket has over and under estimation during light and heavy rains respectively provided that it is also corrected at that given rate of rainfall.

1. Introduction

Over a time period the total amount of precipitation (rainfall) is expressed in millimeters (or inches) as the depth of liquid water which could cover a horizontal portion of the Earth's surface if there was no water loss at all (Simidchiev, D. A., WMO No. 622). It is a meteorological variable with large spatial and temporal variability. An instrument used for point measurement of precipitation is called a precipitation gauge. The standard used mostly is the 20 centimeters or 8 inches gauge. Others use gauges with an opening or collecting area of 200 to 1000 square centimeters. There are several methods of measurement like using a measuring stick to be dipped in a magnifying tube or using a graduated cylinder to measure the amount of rainfall that comes from the collecting funnel or catch. Some use mechanical type like the tipping bucket rain gauges. There are several innovations nowadays like the disdrometer and optical devices.

Due to some instances that there are differences in observations among different rain gauges and knowing the tolerance between the manual rain gauge and the calibrated tipping bucket has made this subject important. The method or formulation to correct the rain gauge using the measuring stick has been illustrated and compared with calibrated tipping bucket.

1.1 Objective

To enhance the accuracy of measurements of the amount of rainfall in an eight (8) inches, or twenty (20) centimeter (standard) rain gauge using the measuring stick is the main purpose of this presentation. This corrected manual rain gauge will then be used as the reference to verify the results of the calibrated tipping bucket rain gauges.

2. Derivation of formula (Mathematical Analysis and Solution)

The following will illustrate the mathematical solutions in correcting the measurements in the said manual rain gauge:

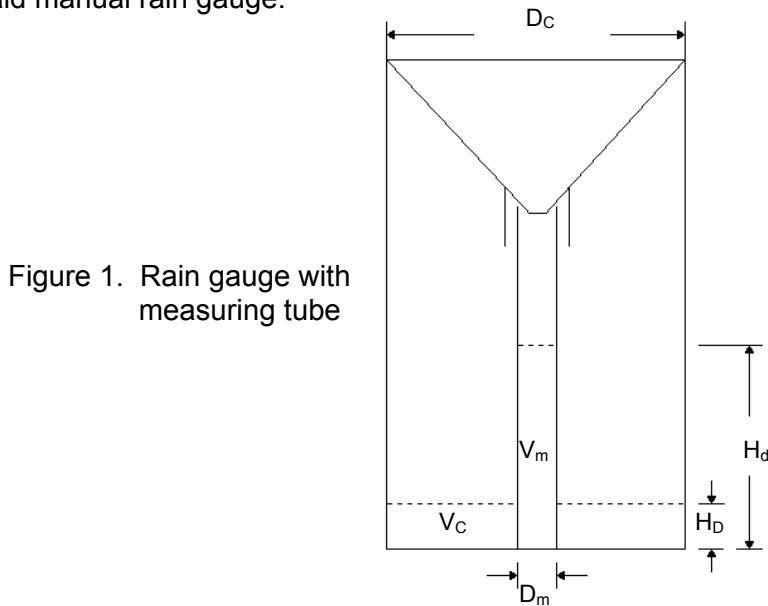

Let:

V_C = volume of rainfall in the collector, cu. mm.

D_C = inside diameter of the collector, mm.

H_D = depth of rainfall in the collector, mm.

V_m = volume of the same quantity of rainfall in the measuring tube, cu. mm.

D_m = inside diameter of the measuring tube, mm.

H_d = depth of the same quantity of rainfall in the measuring tube, mm.

In the design of manual rain gauge, the diameter of the measuring tube may with advantage be made equal to $1/(10)^{1/2}$ of the diameter of the collector (cylinder), hence the depth of rainfall in the collector will be magnified 10 times when poured into the measuring tube as shown below.

Since:

$$V_C = \frac{\pi}{4} (D_C)^2 H_D \quad (1)$$

$$V_m = \frac{\pi}{4} (D_m)^2 H_d \quad (2)$$

But: $V_C = V_m$ and

$$D_m = [1/(10)^{1/2}] D_C \quad (3)$$

Equating (1) & (2) then, $V_C = V_m$

$$\frac{\pi}{4} (D_C)^2 H_D = \frac{\pi}{4} (D_m)^2 H_d$$

$$H_d = (D_C/D_m)^2 H_D \quad (4)$$

Where: $(D_C/D_m)^2$ is the magnification to H_D

Substituting D_m from (3), equation (4) becomes:

$$H_d = [(10)^{1/2} D_C / D_C]^2 H_D$$

Therefore : $H_d = 10 H_D$

Where H_d is the amount of rainfall magnified ten (10) times H_D in the measuring tube which will be measured by means of a measuring stick.

Let :

$$V_{ma} = \frac{\pi}{4} (D_m)^2 I_d$$

Where:

V_{ma} = actual volume in the measuring tube due to immersion of measuring stick, cu. mm.

I_d = indicated depth (measured) due to immersion of measuring stick to the measuring tube, mm.

Therefore:

$$V_{ma} = V_C + V_{10} + V_{11} + V_{12} + \dots + 0 \quad (5)$$

Where:

$V_{10}, V_{11}, V_{12}, \dots$ = are increases in volume due to immersion of measuring stick, mm.

But:

$$V_{10} = T W H_d = \frac{\pi}{4} (D_m)^2 h_1$$

$$V_{11} = T W h_1 = \frac{\pi}{4} (D_m)^2 h_2$$

$$V_{12} = T W h_2 = \frac{\pi}{4} (D_m)^2 h_3$$

⋮
⋮
⋮

$$V_{In} = 0$$

Where:

T = thickness of the measuring stick, mm.

W = width of the measuring stick, mm.

$h_1, h_2, h_3 \dots$ = are height increase of water level due to immersion of measuring stick, in mm.

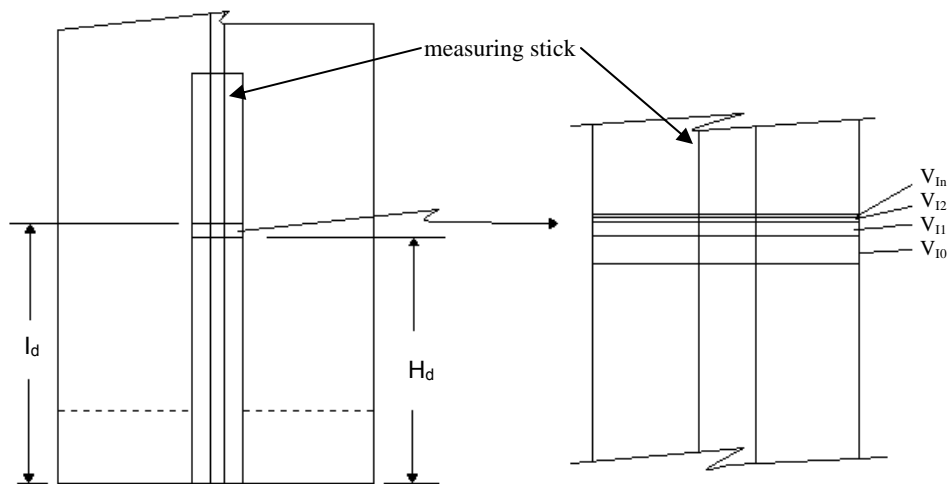

Figure 2. Volume or height increase indicated in the measuring stick

So that by substitutions to equation (5):

$$\frac{\pi}{4} (D_m)^2 l_d = \frac{\pi}{4} (D_C)^2 H_d + T W H_d + T W h_1 + T W h_2 + T W h_3 + \dots + 0$$

$$\begin{aligned} \frac{\pi}{4} (D_m)^2 l_d = & \frac{\pi}{4} (D_C)^2 (D_m / D_C)^2 H_d + T W H_d + \frac{T^2 W^2 H_d}{(\pi/4) (D_m)^2} \\ & + \frac{T^3 W^3 H_d}{[(\pi/4) (D_m)^2]^2} + \frac{T^4 W^4 H_d}{[(\pi/4) (D_m)^2]^3} + \dots + 0 \end{aligned}$$

Then solve for H_d :

$$H_d = \frac{(\pi / 4) (D_m)^2 I_d}{(\pi/4) (D_m)^2 + T W + (T^2 W^2)/[(\pi/4) (D_m)^2] + (T^3 W^3)/[(\pi/4) (D_m)^2]^2 + (T^4 W^4)/[(\pi/4) (D_m)^2]^3}$$

Let:

$$Y = \frac{(\pi / 4) (D_m)^2}{(\pi/4) (D_m)^2 + T W + (T^2 W^2)/[(\pi/4) (D_m)^2] + (T^3 W^3)/[(\pi/4) (D_m)^2]^2 + (T^4 W^4)/[(\pi/4) (D_m)^2]^3}$$

Therefore: $H_d = (Y) I_d$

Where: Y is the multiplying factor to the indicated depth I_d .

If we consider the proportion in equation (4) for D_C and D_m , the overall corrections will be:

$$\text{Corrected Reading} = \frac{10 (Y I_d)}{(D_C/D_m)^2} \quad (6)$$

The corrected reading is multiplied by 10 to compensate for the graduation in the measuring stick which is divided by 10 during measurement. This is when $(D_C/D_m)^2$ is not exactly 10. Equation (6) can also be used for quality control.

Let $B = 10 Y/(D_C/D_m)^2$ and if we consider series of measurements, the total rainfall is represented by:

$$\text{Total Rainfall} = \sum_{k=1}^n B (I_d)_k$$

$$\text{Total Rainfall} = B I_{d1} + B I_{d2} + B I_{d3} + B I_{d4} + \dots + B I_{dn} \quad (7)$$

Where the term $[B I_d]$ could be one measurement reading, or the difference between the latest and previous measurement to get one reading between two measurements (a known height of a full measuring tube during overflow should not be corrected by the multiplying factor B since the measuring stick is not used).

From equation (7), if we consider totals in a day, a week or longer time period, there could be significant result (depending on the multiplying factor B). Remember that the multiplying factor is a constant and inherent to the instrument itself depending on its dimensions.

3. Sample Results

The tests were conducted at the Agromet Station of Science Garden as shown in Figure 3. Since the manual rain gauge is already corrected to its inherent error as a result from equation (6) (measured $RR * 0.933$) and to be measured by an observer, it is used as the reference (unlike the EN13798: 2002 (revised 2010), the standard reference rain gauge pit) to compare with the following three tipping bucket rain gauges (TBRG).

The three rain gauges are the following:

- (A) Tipping Bucket Recorder (mechanical type) - (20 cm. diameter) operated by the Agromet Station (**A-TBR**).
- (B) Tipping Bucket Rain Gauge – (6.5 inches diameter) from AWS of the Instrument Research and Development Unit (**IRAWS**)
- (C) Tipping Bucket Rain Gauge – (20 cm. diameter) located at 22.3 meters distance from the reference manual rain gauge, designated as **Dpaws**.



Figure 3. The manual rain gauge with the three (3) tipping buckets (A), (B), and (C)

The tipping bucket rain gauges were calibrated to conform within the +/- 5% tolerance using the Field Calibration Device as in Figure 4. The (A) and (C) tipping buckets were tested at different rates and found to be within that tolerance while the 6.5 inches diameter tipping bucket was further corrected through its software developed from its calibration result.



Figure 4. The Field Calibration Device (FCD)

To develop the software from the results of calibration, the corresponding multiplier in millimeter per tip to the rates of rainfall in millimeter per hour found in the calibration was first converted to tip per hour. A tip per unit time interval (usually in seconds and converted to tip per hour to be consistent with the unit) will be compared in the program to where it fits to the conditions (the ranges of rate of rainfall in tip per hour) and the corresponding multiplier in millimeter per tip will correct the rainfall amount at that given rate of rainfall in tip per hour (i.e., rainfall = tip * multiplier (in mm./tip) and found the rate = tip/hr * multiplier).

Figure 5. Graphical representations of comparisons

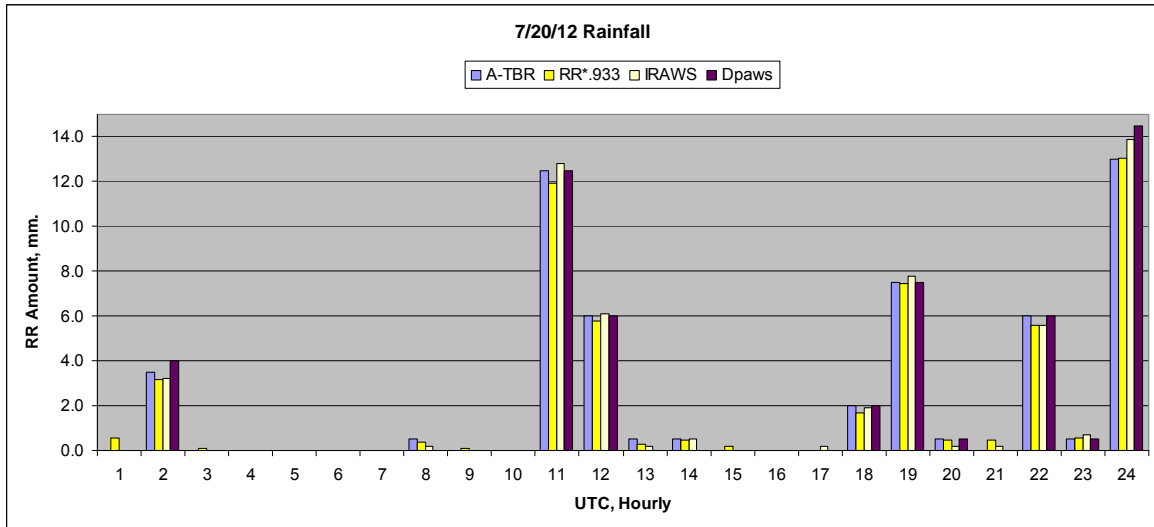

	A-TBR	RR*.933	IRAWS	Dpaws
TOTAL RR 24 hrs.	53.00	52.25	53.50	53.50
% ERROR	1.44	REF (0%)	2.40	2.40

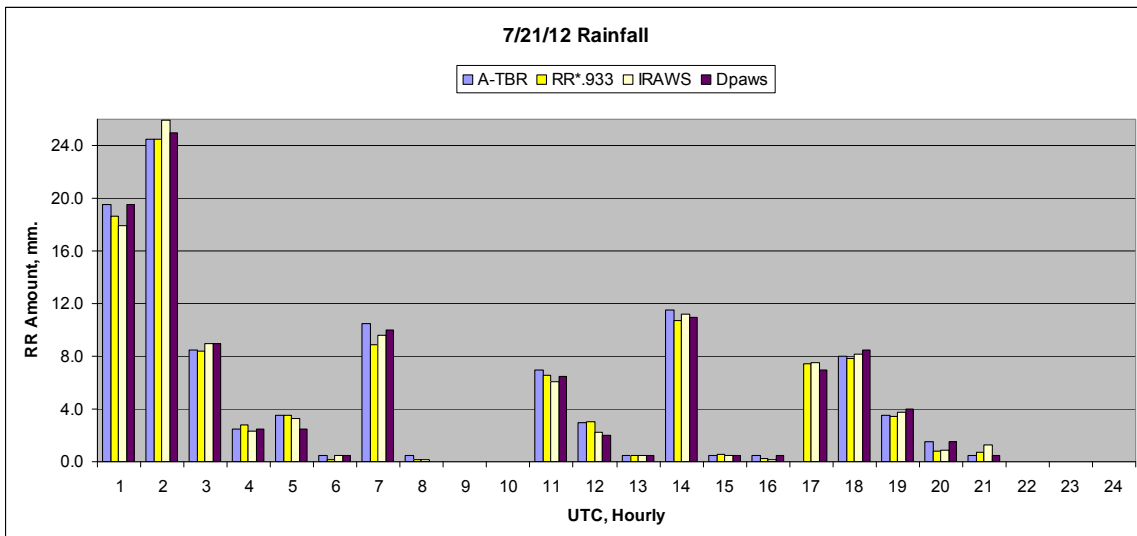

	A-TBR	RR*.933	IRAWS	Dpaws
TOTAL RR 24 hrs.	106.50	109.07	111.10	111.50
% ERROR	-2.35	REF (0%)	1.86	2.23

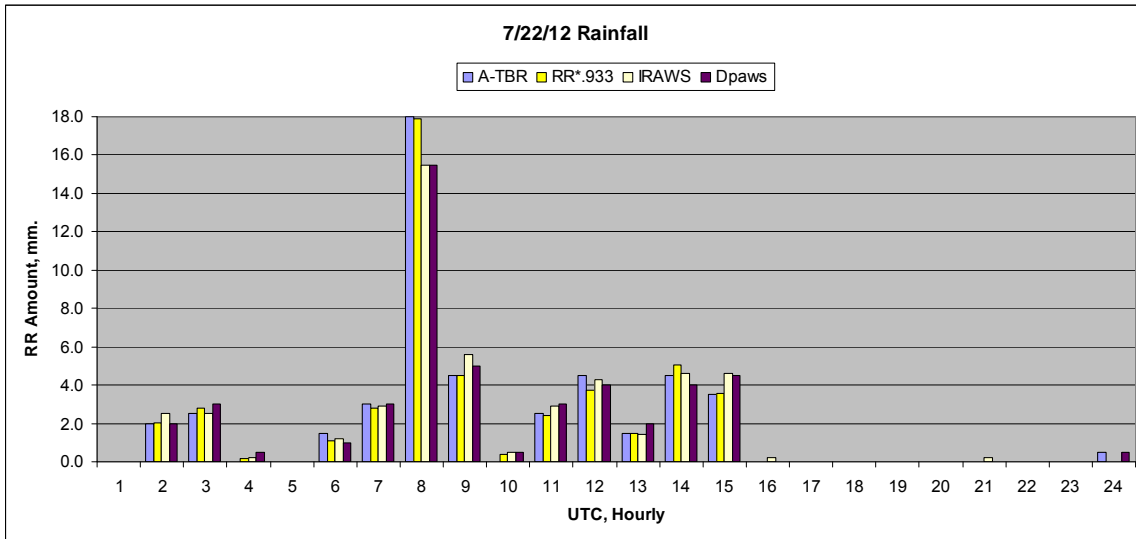

	A-TBR	RR*.933	IRAWS	Dpaws
TOTAL RR 24 hrs.	48.50	47.96	49.10	48.50
% ERROR	1.13	REF (0%)	2.39	1.13

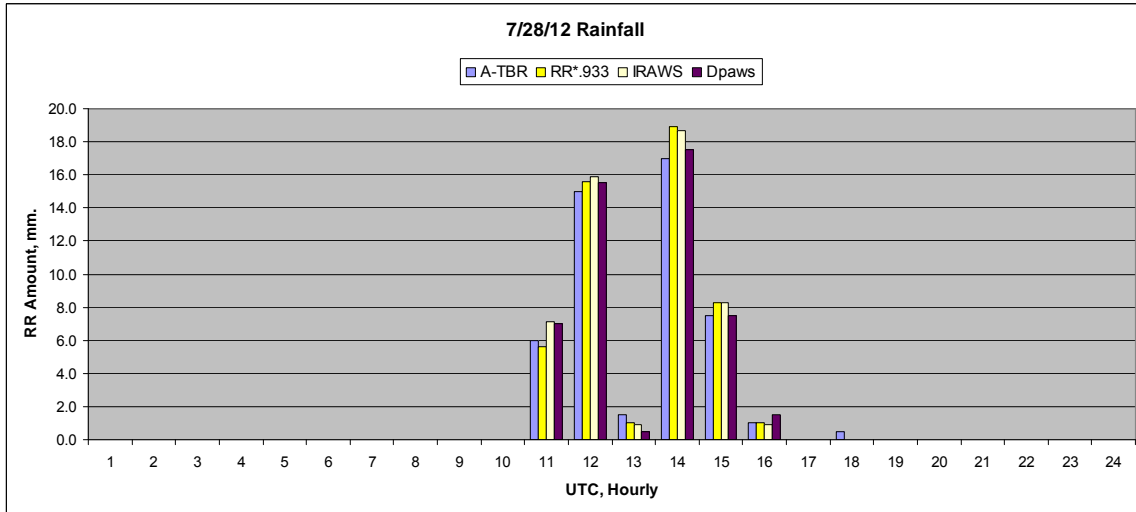

	A-TBR	RR*.933	IRAWS	Dpaws
TOTAL RR 24 hrs.	48.5	50.4	51.8	49.5
% ERROR	-3.8	REF (0%)	2.8	-1.8

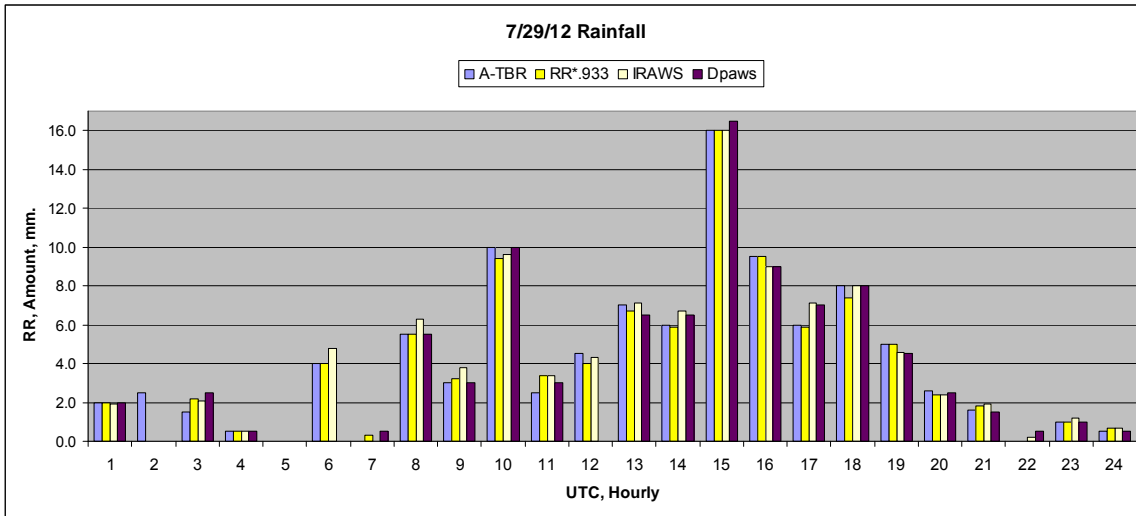

	A-TBR	RR*.933	IRAWS	Dpaws
TOTAL RR 24 hrs.	99.2	96.8	101.6	incomplete
% ERROR	2.5	REF (0%)	5.0	incomplete

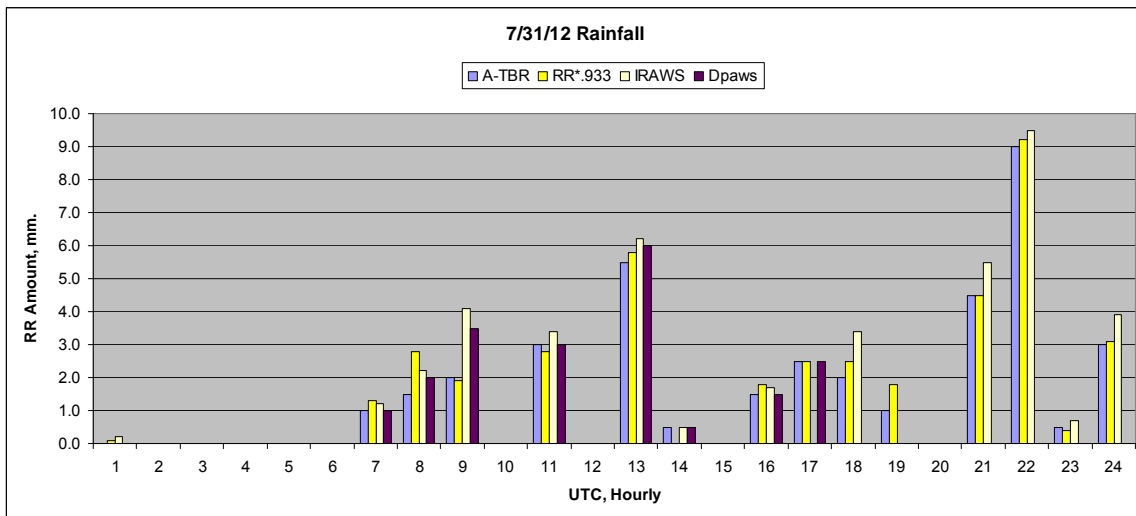

	A-TBR	RR*.933	IRAWS	Dpaws
TOTAL RR 24 hrs.	37.5	40.5	42.5	incomplete
% ERROR	-7.4	REF (0%)	4.938	incomplete

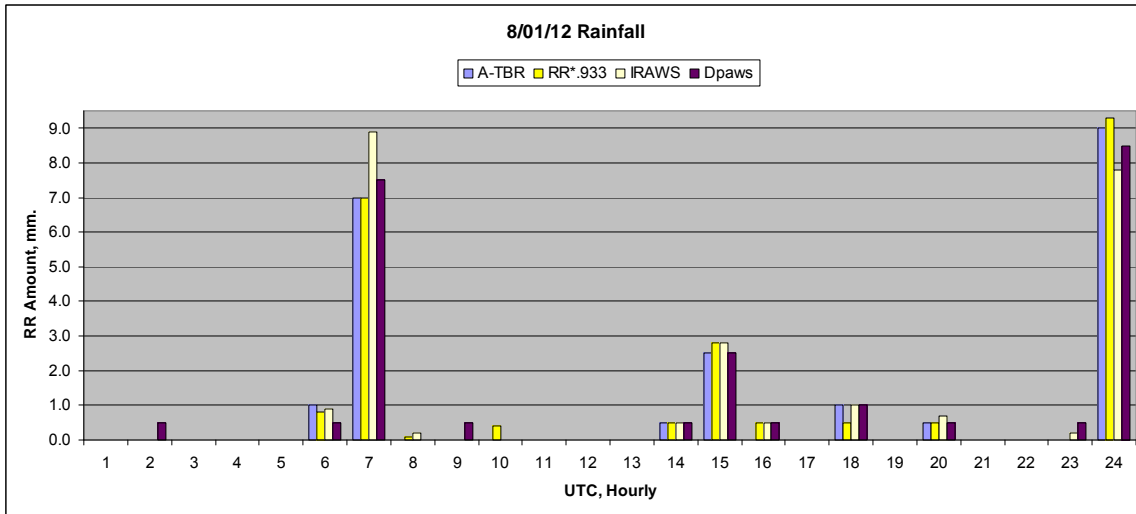

	A-TBR	RR*.933	IRAWS	Dpaws
TOTAL RR 24 hrs.	21.5	22.4	23.5	23.0
% ERROR	-4.0	Ref (0%)	4.9	2.7

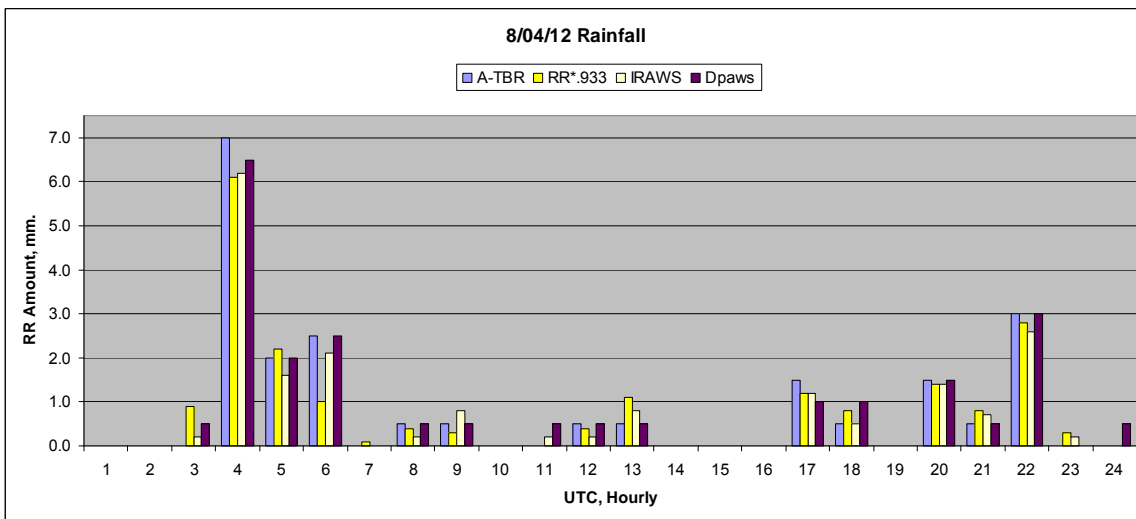

	A-TBR	RR*.933	IRAWS	Dpaws
TOTAL RR 24 hrs.	20.5	19.8	18.9	21.5
% ERROR	3.5	REF(0%)	-4.5	8.6

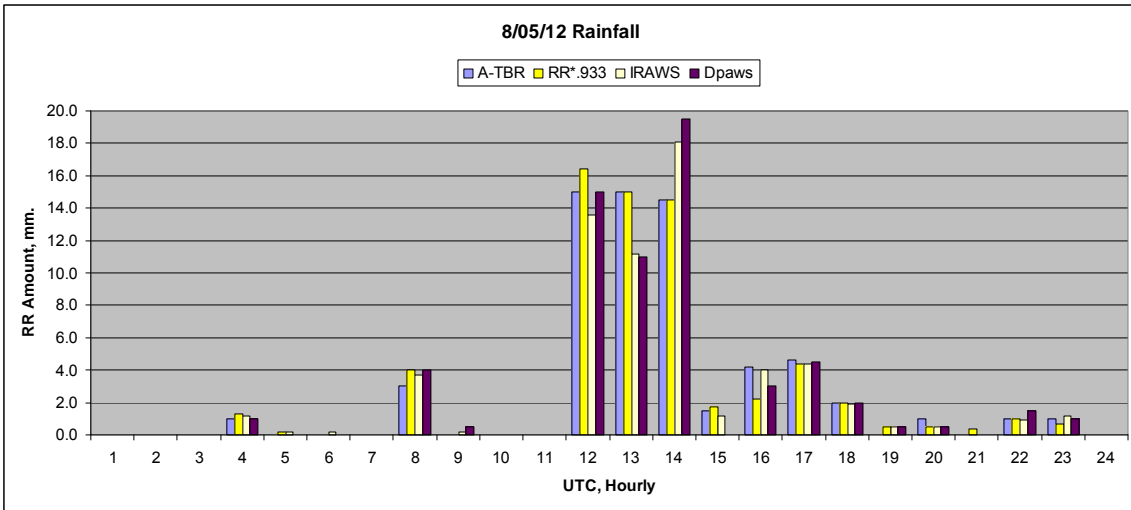

	A-TBR	RR*.933	IRAWS	Dpaws
TOTAL RR 24 hrs.	63.8	64.8	63.0	64.0
% ERROR	-1.5	REF(0%)	-2.8	-1.2

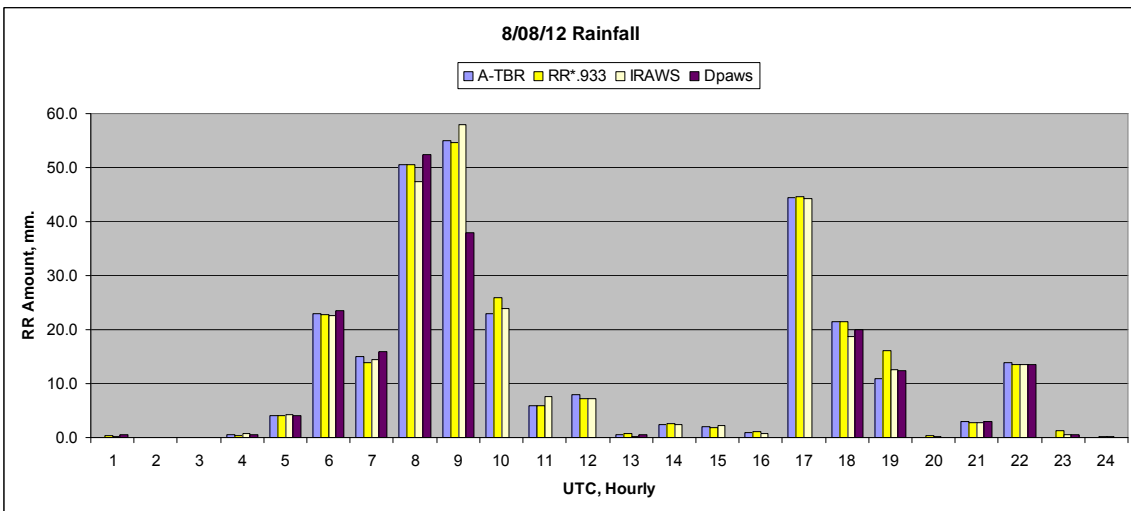

	A-TBR	RR*.933	IRAWS	Dpaws
TOTAL RR 24 hrs.	284.8	292.6	284.6	incomplete
% ERROR	-2.7	REF (0%)	-2.7	incomplete

4. Discussion and Conclusion

The primary purpose of this presentation is to further improve the accuracy of our rainfall measurement. Correction must be applied specifically for the series of measurements and may have significant value when accumulated.

With regards to quality control, the graduation of the measuring stick itself should also be considered for any differences in dimension compared with a standard stick. The diameter of the catch and the measuring tube, or their proportion must also be known. For instance, other rain gauge not using measuring stick, as in graduated cylinder, should be aware of the proportion for the collector and graduated cylinder in order to correct it.

From other point of view, rainfall as it has been known is a very variable weather phenomenon and there are factors that affect it before reaching the rain gauge. One is the wind effect which may mostly contribute to the differences in distribution of rainfall from its cloud producing rain source and may also depend on its location which means that measurement of rainfall may vary in every places (and that we cannot exactly expect the (same) right amount of rainfall) unless we consider point measurement, that is, with limited area of 5 kilometers radius or less (usually small scale) to represent as the measured rainfall. Also, rainfall reaching the ground over an area is calculated by averaging the measurements made at individual gauges spread over the area in question. Other sources of error are wetting and evaporation losses. Synchronization of the time of measurement can also be a problem depending on the type of rain gauges.

Other challenges we are encountering are the dedications of the observers at the field stations in conducting observations and the timely transmission of measured rainfall from AWSs.

5. References

1. WMO LABORATORY INTERCOMPARISON OF RAINFALL INTENSITY GAUGES. De Bilt (The Netherlands), Genoa (Italy), Trappes (France), September 2004 – September 2005. L. Lanza (Italy), M. Leroy (France), C. Alexandropoulos (France), L. Stagi (Italy), W. Wauben (The Netherlands).
2. THE WMO FIELD INTERCOMPARISON OF RAINFALL INTENSITY (RI) GAUGES in Vigna di Valle (ITALY), October 2007- April 2009: relevant aspects and results. Vuerich, E.(1), Monesi, C. (2), Lanza, L.G.(3), Stagi, L(3), Lanzinger, E.
3. The laboratory rain gauges intercomparison: Results and operational network applications. Christophe Alexandropoulos and Muriel Lacombe (France).
4. WMO Guide to Meteorological Instruments and Methods of Observation. Preliminary seventh edition, WMO-No. 8, 2006
5. Compendium of Lecture Notes on Meteorological Instruments for Training Class III and Class IV Meteorological Personnel. Prepared by Dr. D. A. Simidchiev, Vol. 1, WMO-No. 622.