

# Underway Measurements on merchant ships

S.O.T. V Meeting, Geneve  
18 - 22 May, 2009

# Plan

- **History**
- **The fleet 1998 – 2009**
- **The Network, 2008**
- **Instrumentation**
  - Salinity
  - XBT
  - CO<sub>2</sub>
- **Data**
  - Salinity
  - XBT
  - CO<sub>2</sub>

# History

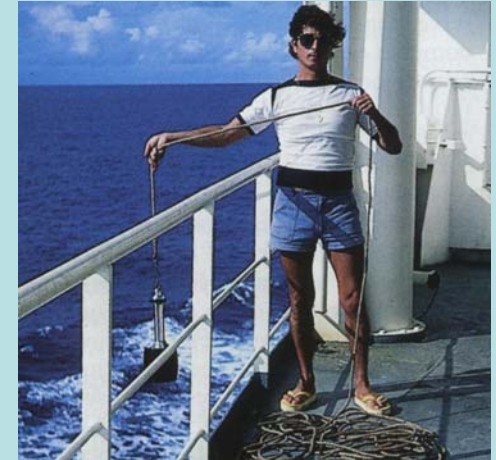

- 1957 T, S (buckets)
- 1978 XBT, 400 m
- 1985 XBT, 800 m
- 1990 TSG
- 2006  $p\text{CO}_2$

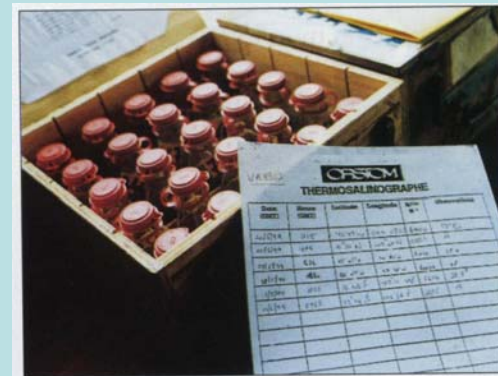

# The fleet 1998 - 2009

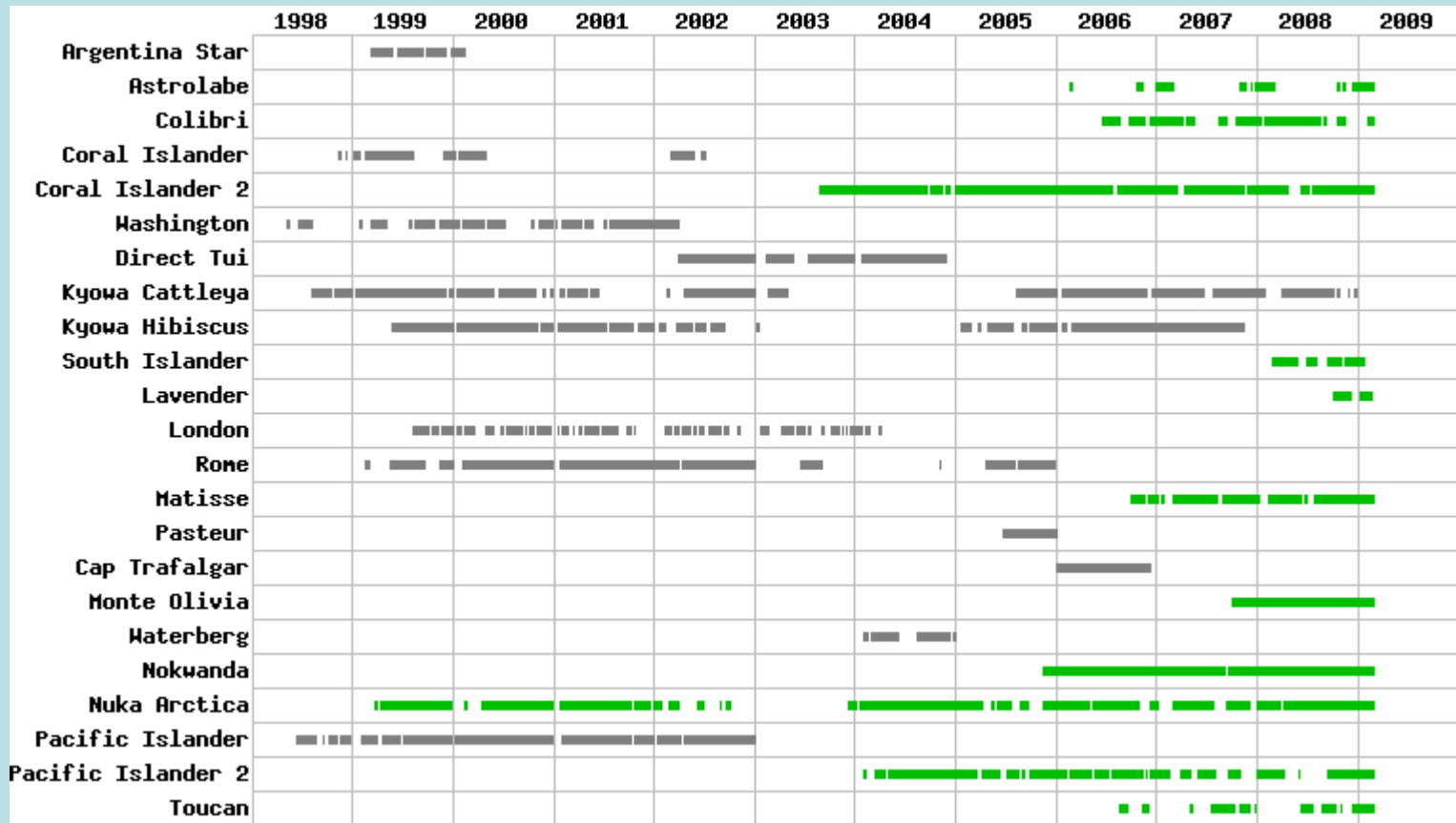

- Leaving in 2008-09: Kyowa Cattleya, Monte Olivia (to be replaced)
- New in 2008-2009: South Islander, Lavender, Tropical Islander.

# The network, 2008

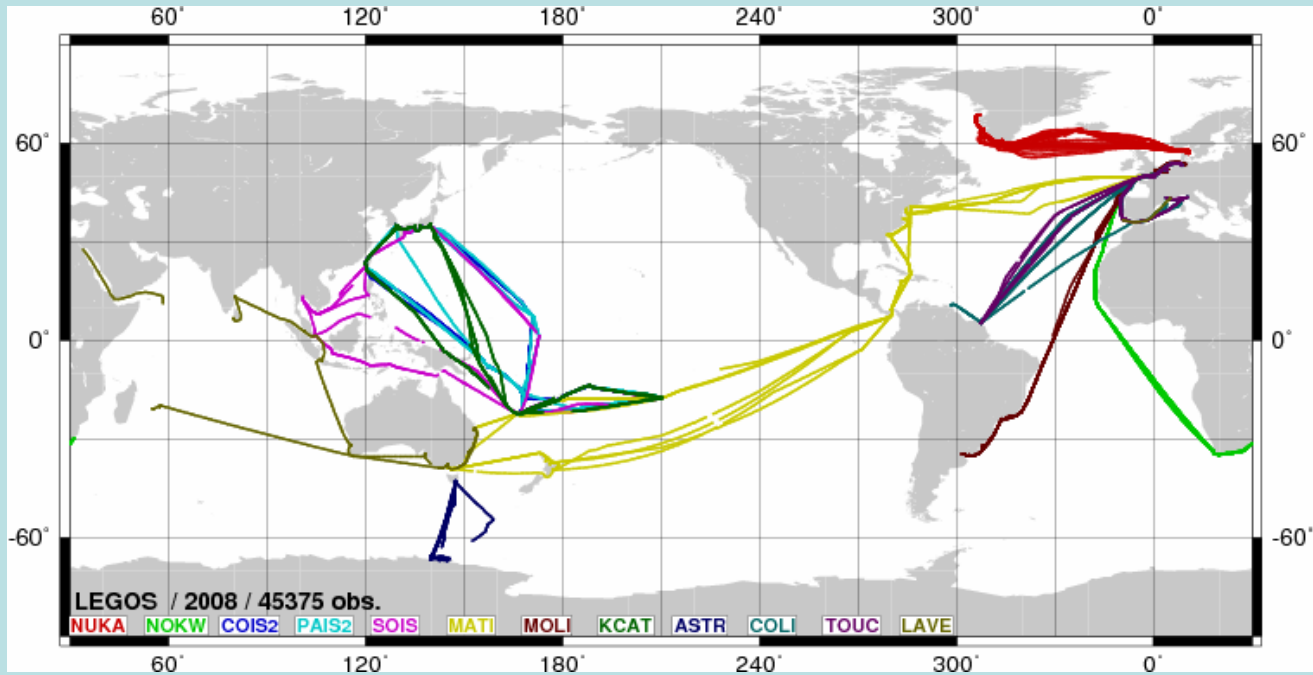

TSG



XBT



pCO<sub>2</sub>

# Instrumentation

- 11 TSG SBE 21 – Inmarsat-C transmitter
  - AX01, AX03, AX10, AX11, AX15, AX20
  - IX01, IX12, IX15, IX26
  - PX04, PX05, PX08, PX12, PX17, PX30, PX53
- 4 XBT Devil – Argos transmitter
  - AX01, AX15, AX20
  - PX04, PX05, PX12, PX53
- 2 pCO<sub>2</sub> analysers – Iridium transmitter
  - AX11, AX20

# Instrumentation

## Salinity



Safmarine Nokwanda

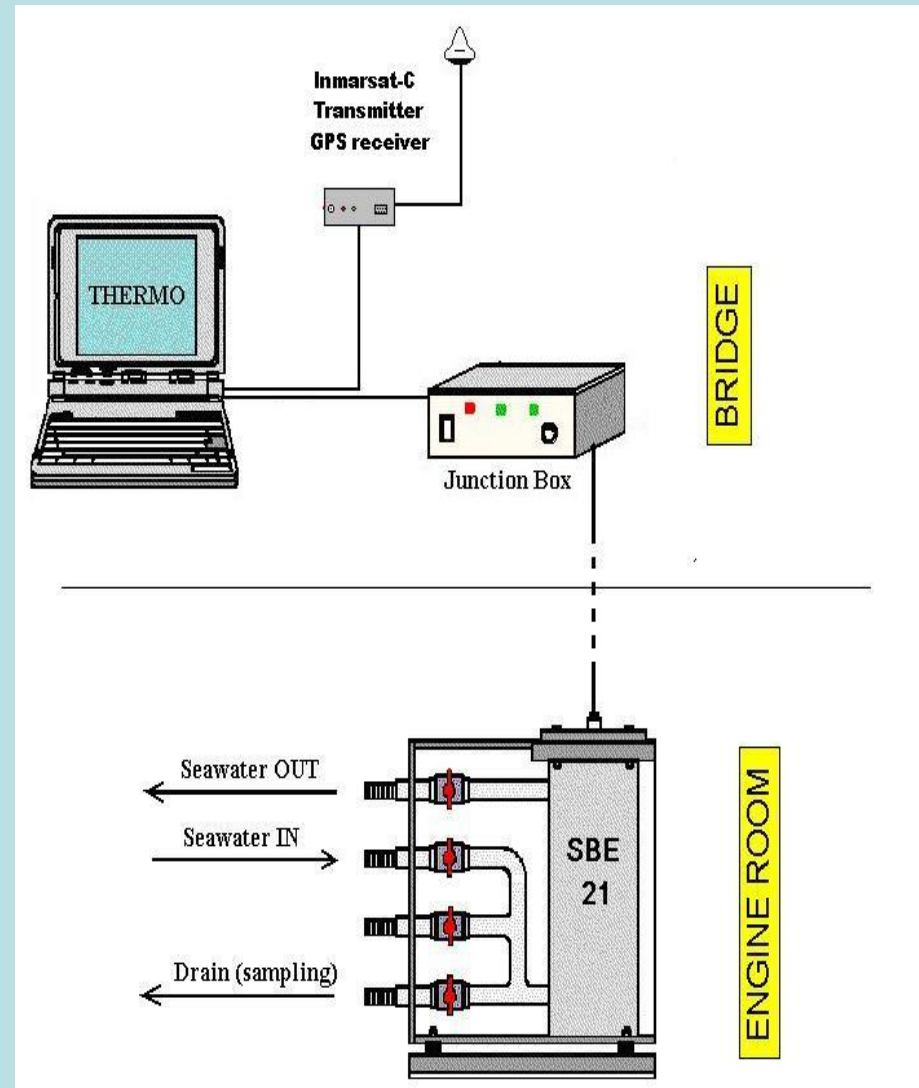



# Instrumentation

## XBT

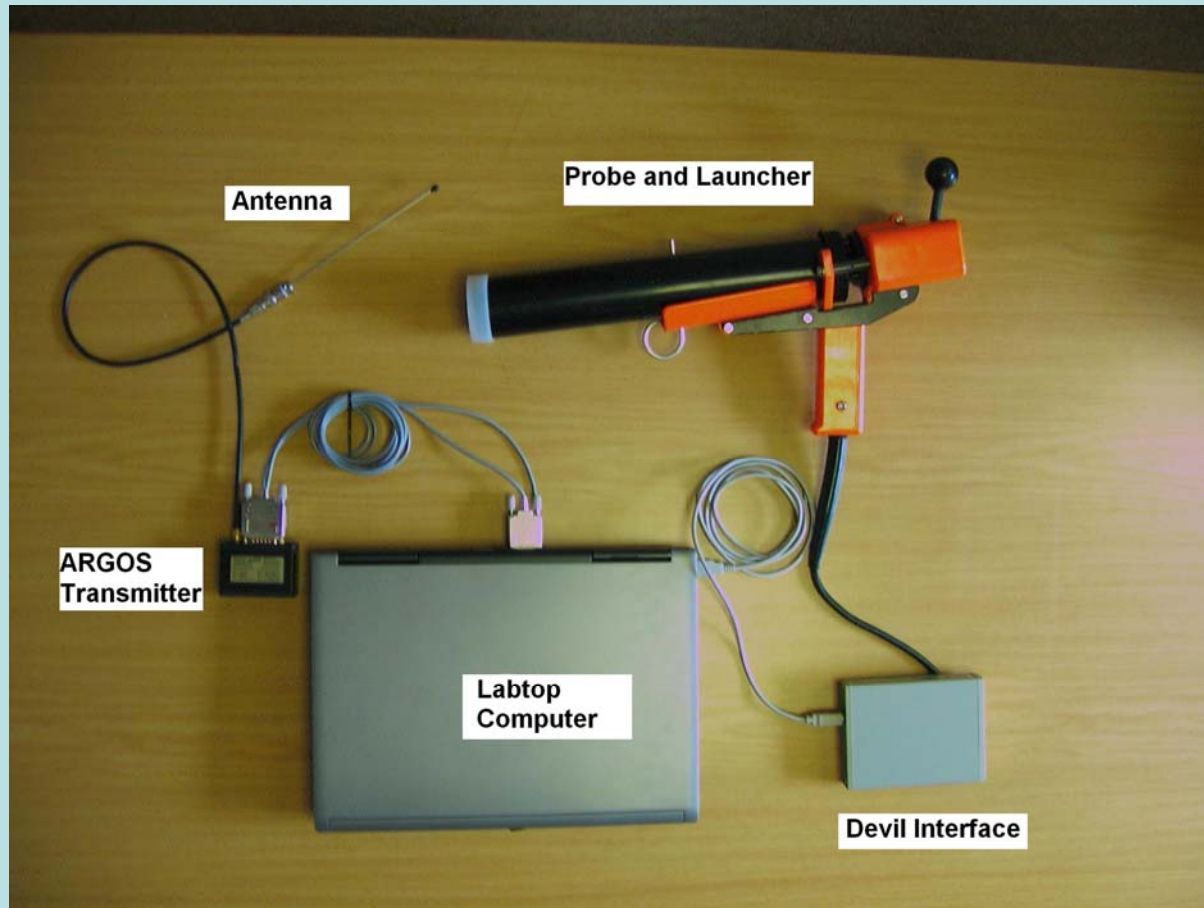



# Instrumentation

## CO<sub>2</sub> fugacity

Infra-red Analyser  
(Craig Neill system)

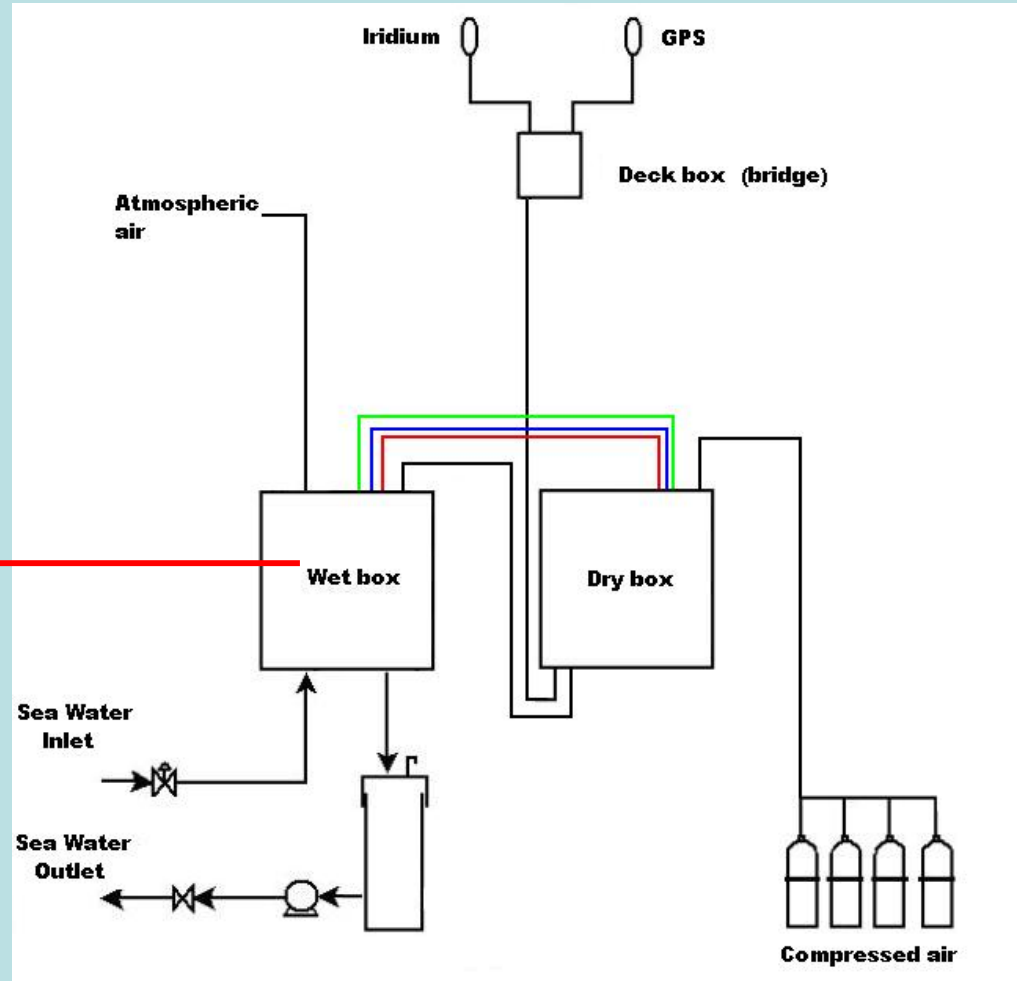

# Data

## TSG / Real time

- T,S in real time.
- Restricted access (asked by some companies)

<http://www.legos.obs-mip.fr/observations/sss/>

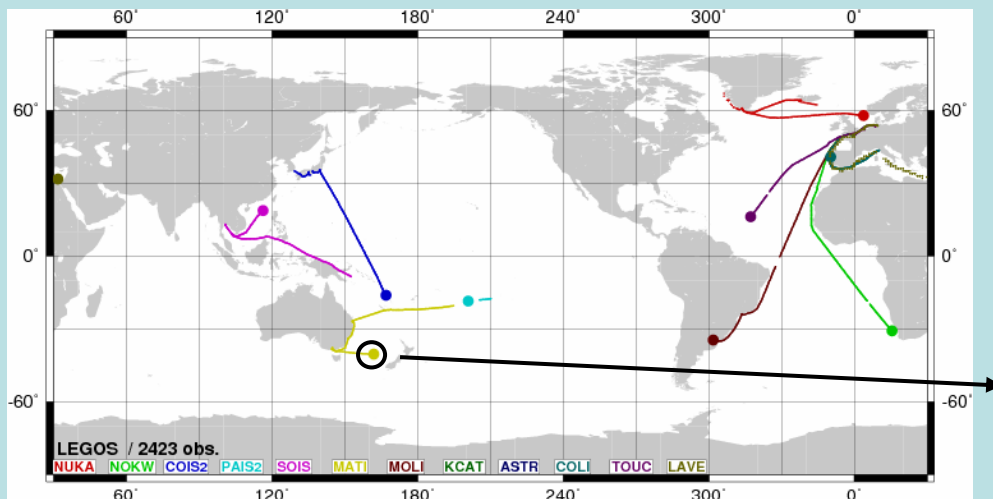

21/03/09 - 04/04/09

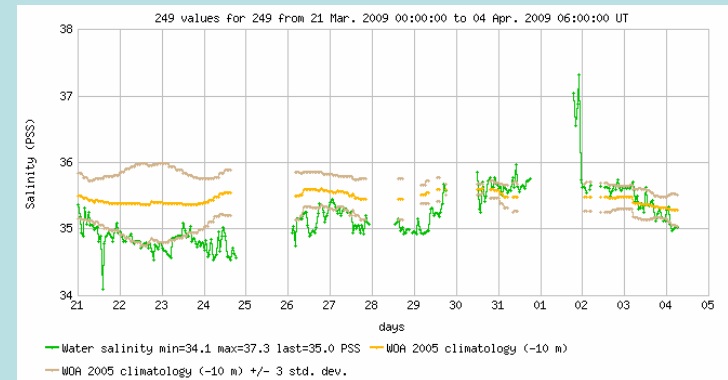

S

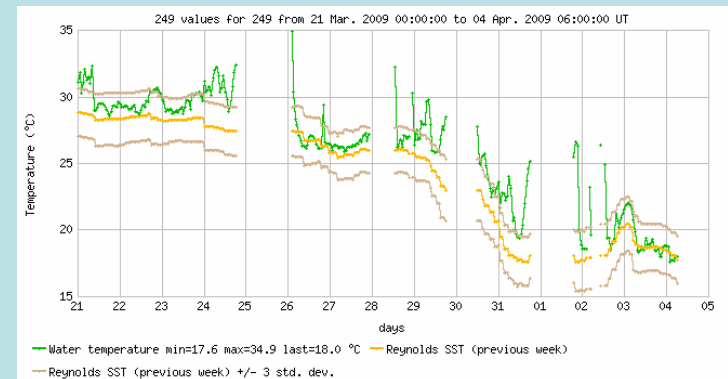

T

# Data

## TSG / delayed mode

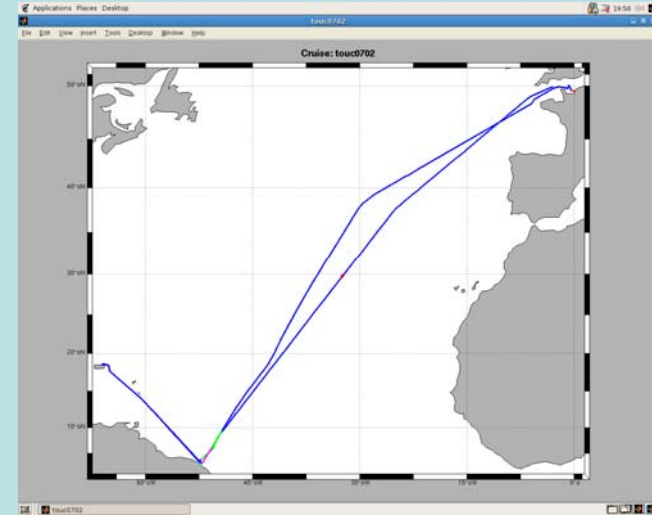
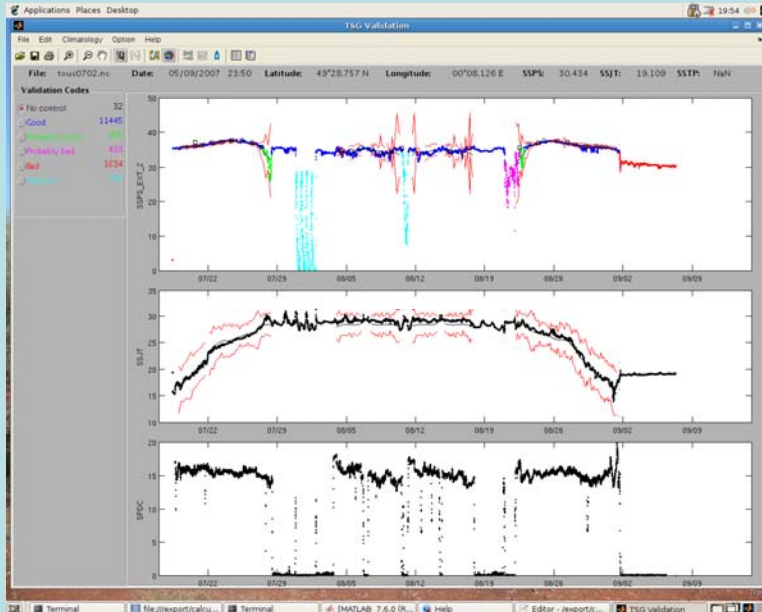

- Software: TSG-QC
- Proposed correction using buckets/ ARGO data

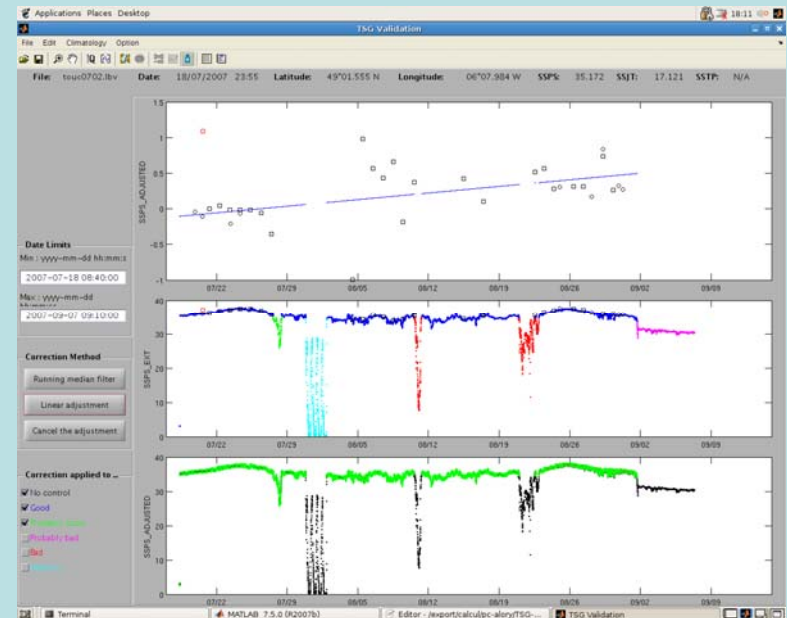

# Data XBT

## M/V Coral Islander 2 - 2008

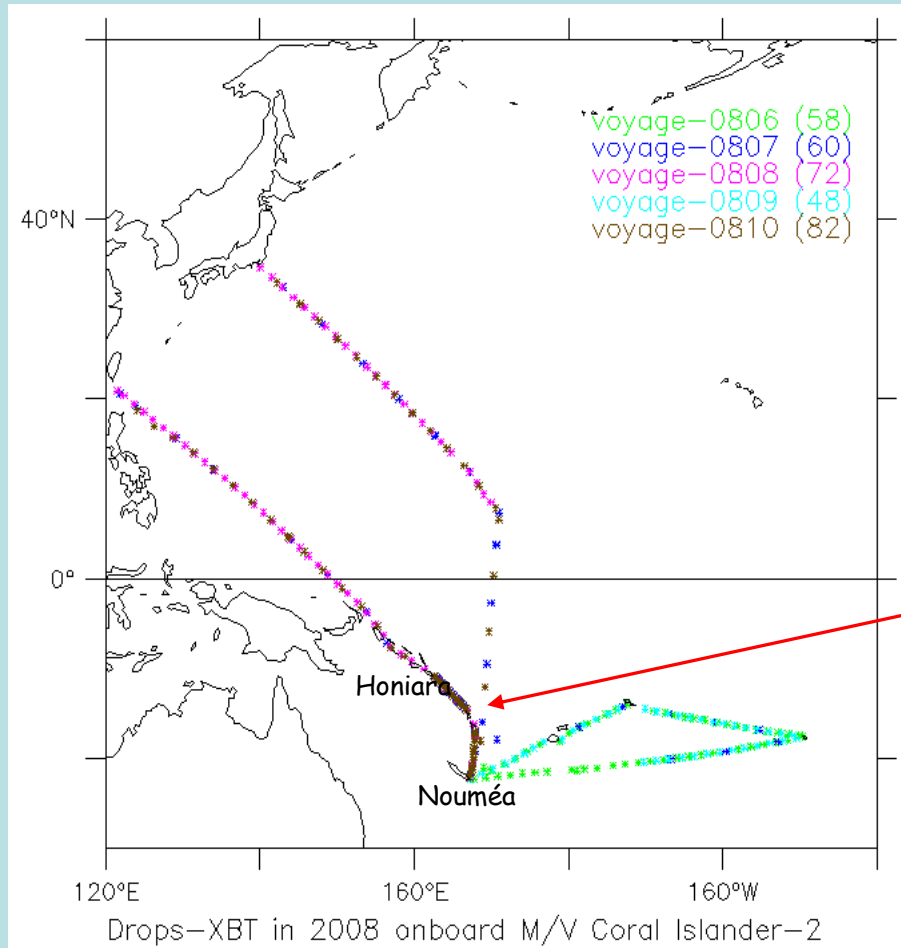

Links to SPICE (research program in CLIVAR):

- HD transects between Nouméa and Honiara
- Recommendations done in the white paper by Goni *et al.* for the OceanObs'09

contact: Dr Christophe Maes (IRD)  
[christophe.maes@noumea.ird.nc](mailto:christophe.maes@noumea.ird.nc)

# Data pCO<sub>2</sub>



Monte Olivia

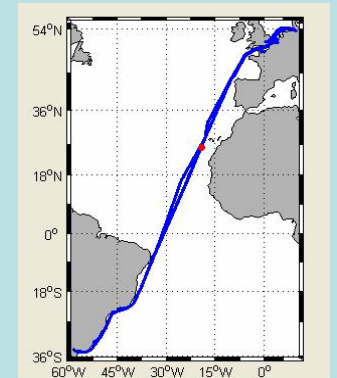
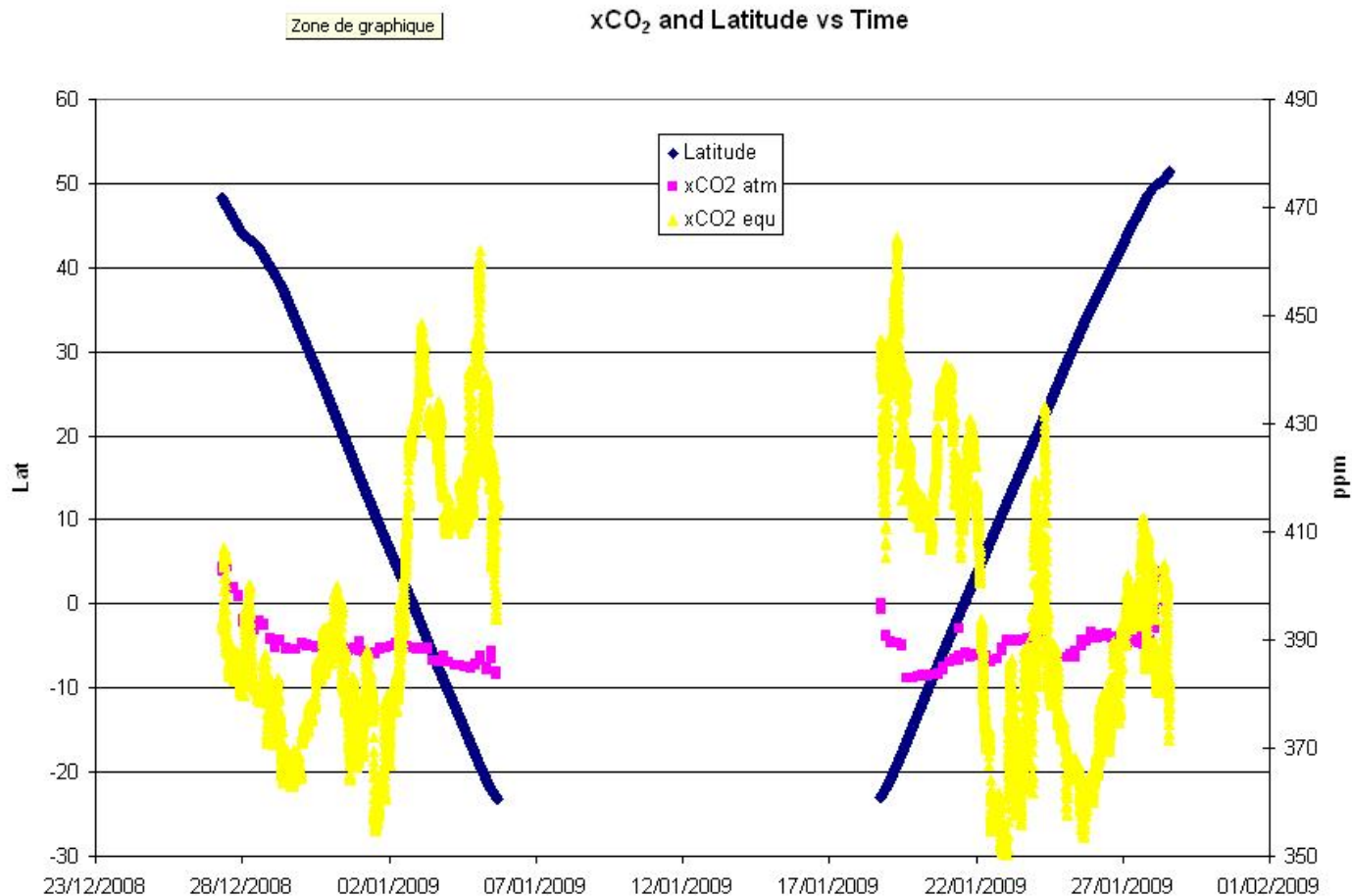



# New in 2008: CMA CGM Lavender

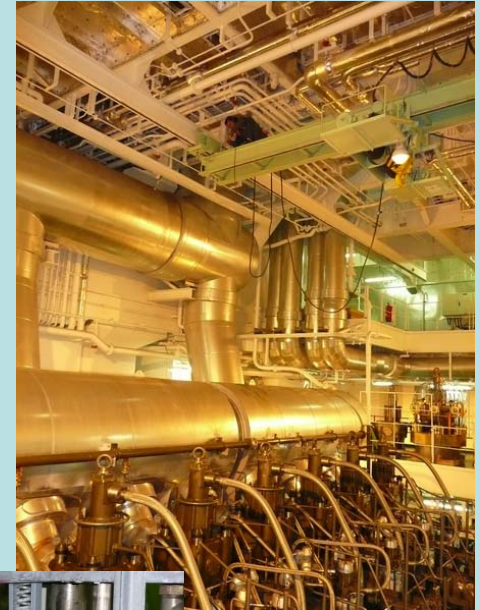
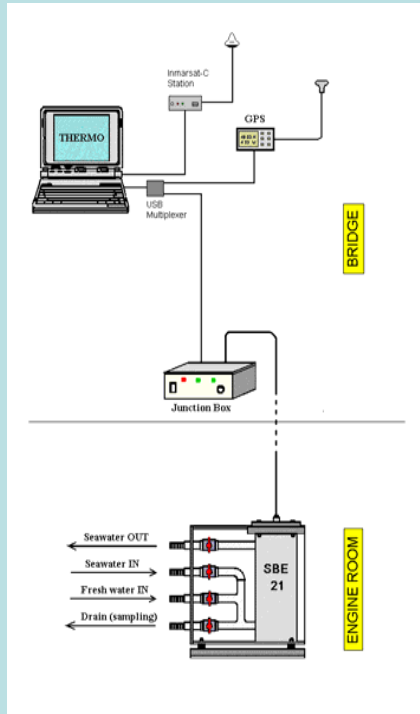
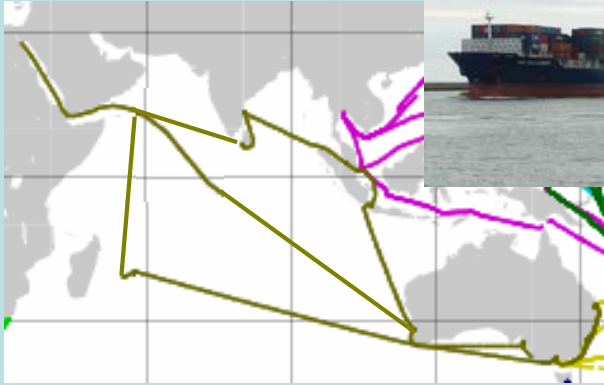



# Conclusion

- What future for XBT?
  - LDX ?
  - FRX ?
  - HDX ? Difficult to drop each 2 hours.  
Requires a rider.